



City of Fort Collins

Administrative Services

Purchasing Division

BID PROPOSAL

BID # 5796

OPENING DATE: 2:00 P.M. (OUR CLOCK) JUNE 27, 2003

WE HEREBY ENTER OUR BID FOR THE CITY OF FORT COLLINS' REQUIREMENTS FOR **PURCHASE AND REMOVAL OF 15 KV ELECTRICAL SWITCHGEAR - OVERLAND TRAIL SUBSTATION** PER THE BID INVITATION AND ANY REFERENCED SPECIFICATIONS.

All equipment is sold on an "as is", "where is" basis with no warranty expressed or implied. The awarded bidder shall be responsible for all transportation (including loading) and any associated fees. All quotations shall be FOB City of Fort Collins, Colorado. Any special requirements, for shipment or otherwise, must accompany your bid. Any exceptions shall be clearly identified.

The City of Fort Collins reserves the right to negotiate the final sales price.

A copy of the Bid Proposal and Specifications may be obtained as follows:

1. Visit Purchasing at 215 North Mason St., 2nd floor, Fort Collins, Co., and request a copy of the Bid.
2. Contact Purchasing at (970) 221-6775, provide e-mail address or street address and the bid proposal will be sent.

Any proposal deemed to be collusive or a sham proposal will be rejected and reported to authorities as such. Your authorized signature of this proposal assures that such proposal is genuine and is not a collusive or sham proposal.

The City of Fort Collins reserves the right to reject any and all proposals and to waive any irregularities or informalities.

Purchasing questions should be directed to: Opal F. Dick, CPPO, Senior Buyer, Telephone number (970) 221-6778, e-mail: odick@fcgov.com

Technical questions should be directed to: Matt Haag, Fort Collins Utilities, Light and Power Operations Dept., Telephone number (970) 416-2772, e-mail: mhaag@fcgov.com

Sincerely,

James B. O'Neill II, CPPO, FNIGP

Director of Purchasing & Risk Management

PROPOSAL FOR PURCHASE AND REMOVAL OF 15KV ELECTRICAL SWITCHGEAR

OVERLAND TRAIL SUBSTATION

BID # 5796

SPECIFICATIONS & INSTRUCTIONS FOR PROPOSALS

1.1 GENERAL. These instructions apply to the preparation of proposals for the purchase and removal of 15KV electrical switchgear as set forth in the following text and attached drawings for the City of Fort Collins Utilities, hereinafter referred to as "Owner."

1.2 CONTRACTOR'S QUALIFICATIONS. In order for their proposals to be considered, contractor must meet the following qualifications:

- Maintains a permanent place of business;
- Has available plant and equipment to perform the work;
- Has technical knowledge and practical experience in work of the type specified;
- Has available, the organization and qualified personnel to perform the work;
- Has adequate financial status to meet the financial obligations incident to the work;
- Has no just or proper claims pending against him or his work;
- Has removed other facilities of similar type and of equal or greater size and complexity

1.3 PROPOSALS. One (1) copy of the proposal shall be prepared and submitted, with these specifications attached. Proposals which are not prepared and submitted in accordance with these instructions will imply that the contractor does not intend to comply with the specifications and may be considered void.

1.3.1 Preparation. Each proposal shall be prepared using the proposal and data forms that area part of this document. Entries on the proposal shall be typed or legibly written in black ink. All prices shall be stated in words and figures.

The contractor shall list in the space provided on the proposal form all exceptions or conflicts between his proposal and these specifications. If the bidder takes no exceptions, he shall write "None" in the space provided. Proposals which do not comply with this requirement may be deemed irregular and nonresponsive and may be rejected at the discretion of the Owner.

1.3.2 Signatures. Each bidder shall sign the proposal with his usual signature and shall give his full business address.

1.3.3 Submittal. Proposals shall be submitted in a sealed envelope before 2:00 p.m.(Our Time) June 27, 2003 and addresses in the following manner:

If Delivered:

City of Fort Collins
Purchasing Division
215 North Mason Street, 2nd Floor
Fort Collins, CO. 80524

If Mailed:

City of Fort Collins
Purchasing Division
P.O. Box 580
Fort Collins, CO. 80522-0580

A single proprietary interest shall not submit multiple proposals for the same work, even though the individual proposals are submitted under different names. The Owner reserves the right to reject all proposals so submitted.

1.3.4 Withdrawal. Proposals may be withdrawn, altered, and resubmitted, at any time before the opening date. Proposals may not be withdrawn, altered, or resubmitted within 60 days thereafter.

1.4 TAXES, PERMITS, AND LICENSES. Each contractor shall be responsible for determining the applicable taxes, permits, and licenses. The Owner does not require any permits or licenses to work in the substation.

1.5 TIME OF COMPLETION AND SCHEDULE. The time of completion of the work is a basic consideration of the proposal. The contractor will be given a maximum of seven (7) consecutive days to completely remove the electrical switchgear from the site. Exceeding the seven days will not be acceptable and the contractor should not submit a proposal if the timeframe cannot be met.

1.6 LOCAL CONDITIONS. The contractor shall visit the site of the work to determine all the conditions and factors which would affect the work and the cost thereof, including the arrangement and conditions of existing structures, affecting or affected by the proposed work, the availability and cost of labor, and facilities for transportation, handling, and storage of materials and equipment.

It must be understood and agreed that all such factors have been investigated and considered in the preparation of every proposal submitted. No claims for financial adjustment to any contract awarded for the work under these specifications and documents will be permitted by the Owner which are based on lack of prior information or its effect on the cost of the work.

1.7 INTERPRETATION OF SPECIFICATIONS. If a contractor is in doubt as to the true meaning of any part of the documents, he may contact the Engineer for clarification.

1.8 ACCEPTANCE AND REJECTION OF PROPOSALS. The Owner reserves the right to accept the proposal which, in its judgement is the lowest and best proposal, taking into account all the proposal requirements; to reject any and all proposals; and to waive irregularities and informalities in any proposal that is submitted. Proposals received after the specified time of opening shall be disqualified.

1.9 PROTECTION OF WORK. The Contractor shall be solely responsible for the protection of his work until its final acceptance by the Owner.

The Contractor shall have no claim against the Owner or the Engineer because of damage or loss to the Contractor's work or equipment.

In the event that the Contractor's work is damaged by another party not under his control, the Contractor shall make his claim directly with the party involved.

1.10 PROTECTION OF EXISTING FACILITIES. The Contractor shall be responsible for any damage to existing facilities which results from removal of the electrical switchgear from the substation site. All repair work shall be acceptable to the Owner.

1.11 SUBCONTRACTORS. The contractor shall be responsible for the work of all and any damage resulting from their work.

1.12 COOPERATION WITH OWNER. The performance of construction shall be mutually agreed upon with respect to daily schedules of the Owner's personnel. While working in the substation, an Owner's representative shall be present at all times.

1.13 WORKING IN ENERGIZED SUBSTATION FACILITIES. The Contractor will be working in an energized substation facility in proximity to lethal high voltage substation equipment. **Extreme care** must be exercised while performing the switchgear removal and while using cranes and other salvage equipment. The Contractor shall be completely responsible for the safety of his personnel and shall employ all methods necessary to achieve such safety. These methods shall include, but not be limited to barriers, warning signs and guards, and preventing unauthorized access to the substation site.

1.14 SCOPE OF WORK. The work shall include Contractor furnished equipment, labor, and supervision for the complete removal of electrical switchgear from the Overland Trail Substation site. The switchgear is located inside of the control building with limited access. All external cables will be cleared from the switchgear and the switchgear shall be certified de-energized prior to notification of the contractor to proceed. No equipment or personnel for the removal work will be provided by the Owner.

1.15 PAYMENT FOR SWITCHGEAR. The Contractor shall state a lump sum amount for the purchase of the switchgear. The lump sum shall be the final amount to be paid to the Owner after all contractor removal expenses are taken into account and shall be stated in the proposal. There will be no payments made to the contractor for any work associated with the removal of the switchgear. A payment in the form of a cashier's check shall be delivered to the Owner three (3) days prior to commencement of the removal work. The check shall be made out to:

City of Fort Collins Utilities - L&P Operations Department

**BILL OF MATERIAL
FOR
15KV SWITCHGEAR BREAKERS
OVERLAND TRAIL SUBSTATION**

Item	Description	Qty.
1	Mfgr: Westinghouse Type: De-Ion Air Circuit Breaker Model: 150-DHP-500 Style: 151D746G11 Control: 125 VDC motor and trip coil Ratings: 95 KV-BIL; 13.8 KV; 1200 Amps	8
2	Mfgr: Westinghouse Type: De-Ion Air Circuit Breaker Model: 150-DHP-500 Style: 151D746G38 Control: 125 VDC motor and trip coil Ratings: 95 KV-BIL; 13.8 KV; 3000 Amps	2
3	Mfgr: Westinghouse Type: De-Ion Air Circuit Breaker Model: 150-DHP-500 Style: 449D903G12 Control: 125 VDC motor and trip coil Ratings: 95 KV-BIL; 13.8 KV; 1200 Amps	2
4	Mfgr: Westinghouse Type: Grounding Breaker Model: 150-DHP-750C Style: 49Y8078G Control: 125 VDC motor Ratings: 15 KV; 1200/2000 Amps	1

PROPOSAL (cont.)

P.1 LUMP SUM PRICE

The contractor hereby proposes to pay a lump sum amount as set forth in the Specifications and Instructions for the purchase and removal of the electrical switchgear.

_____ (\$ _____)
(Price in Words)

The undersigned hereby certifies that he has visited the site of the proposed work and has familiarized himself with the conditions affecting the work.

The above price is firm.

In submitting this proposal it is understood that the Owner reserves the right to reject any and all proposals, and it is further understood that this proposal may not be withdrawn during a period of 60 days after the proposal due date.

THE UNDERSIGNED CONTRACTOR HEREBY certifies (a) that all conflicts and exceptions have been noted or listed as directed; (b) that this proposal is genuine and is not made in the interest of, or in behalf of, any undisclosed person, firm or corporation, and is not submitted in conformity with any agreement or rules of any group, association, organization, or corporation; (c) that he has not directly or indirectly induced or solicited any other contractor to put in a false or sham bid; (d) that he has not solicited or induced any person, firm, or corporation to refrain from submitting a proposal; and (e) that he has not sought by collusion to obtain for himself any advantage over any other contractor or over the Owner.

Dated at _____ this _____ day of _____.

Contractor _____

Business Address of Contractor _____

State of Incorporation _____

Address of Principal Office _____

MAIN BREAKER NO.1

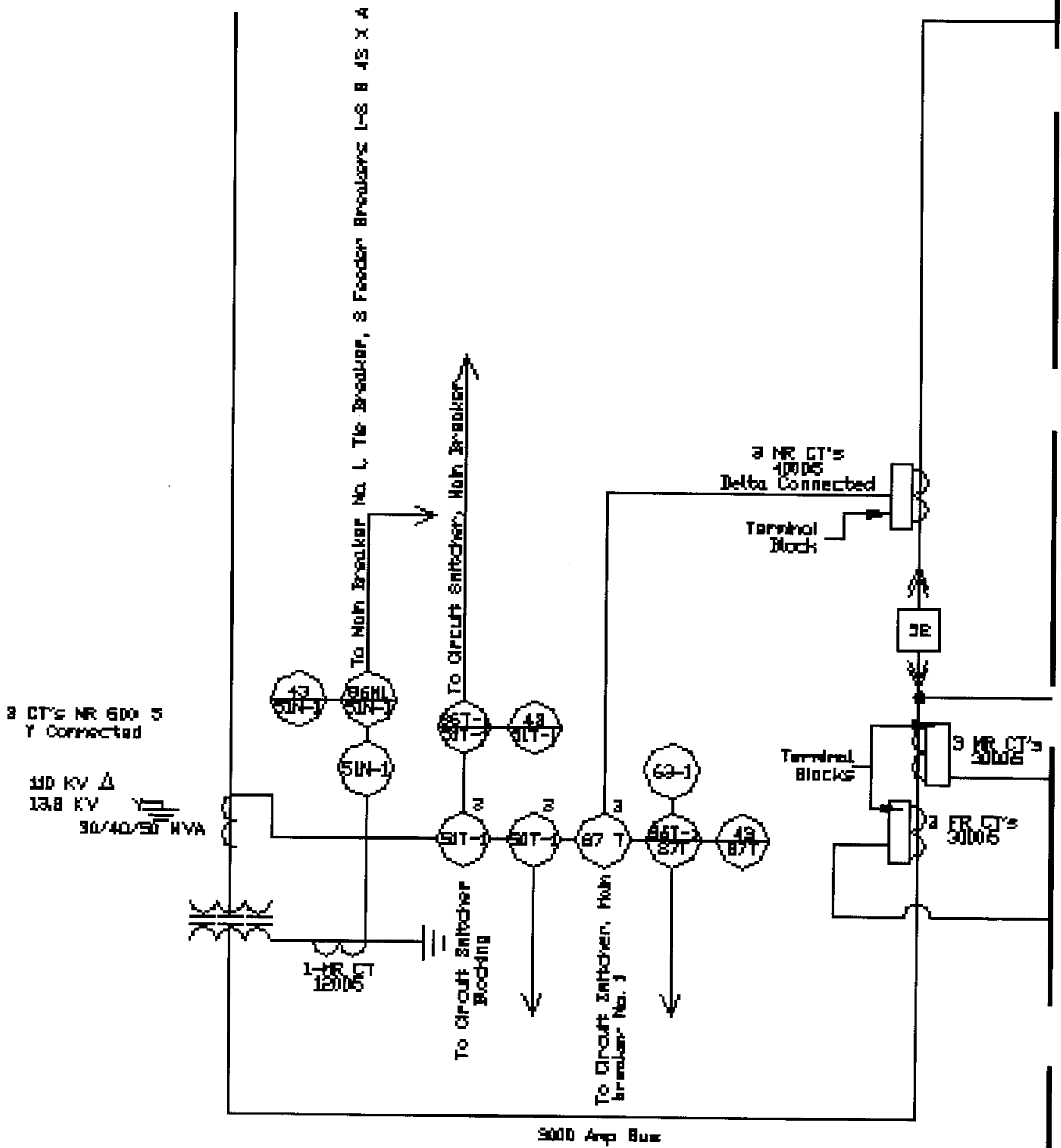

FEEDER NO. 1A - 8A TYP.

3000 Amp BUS

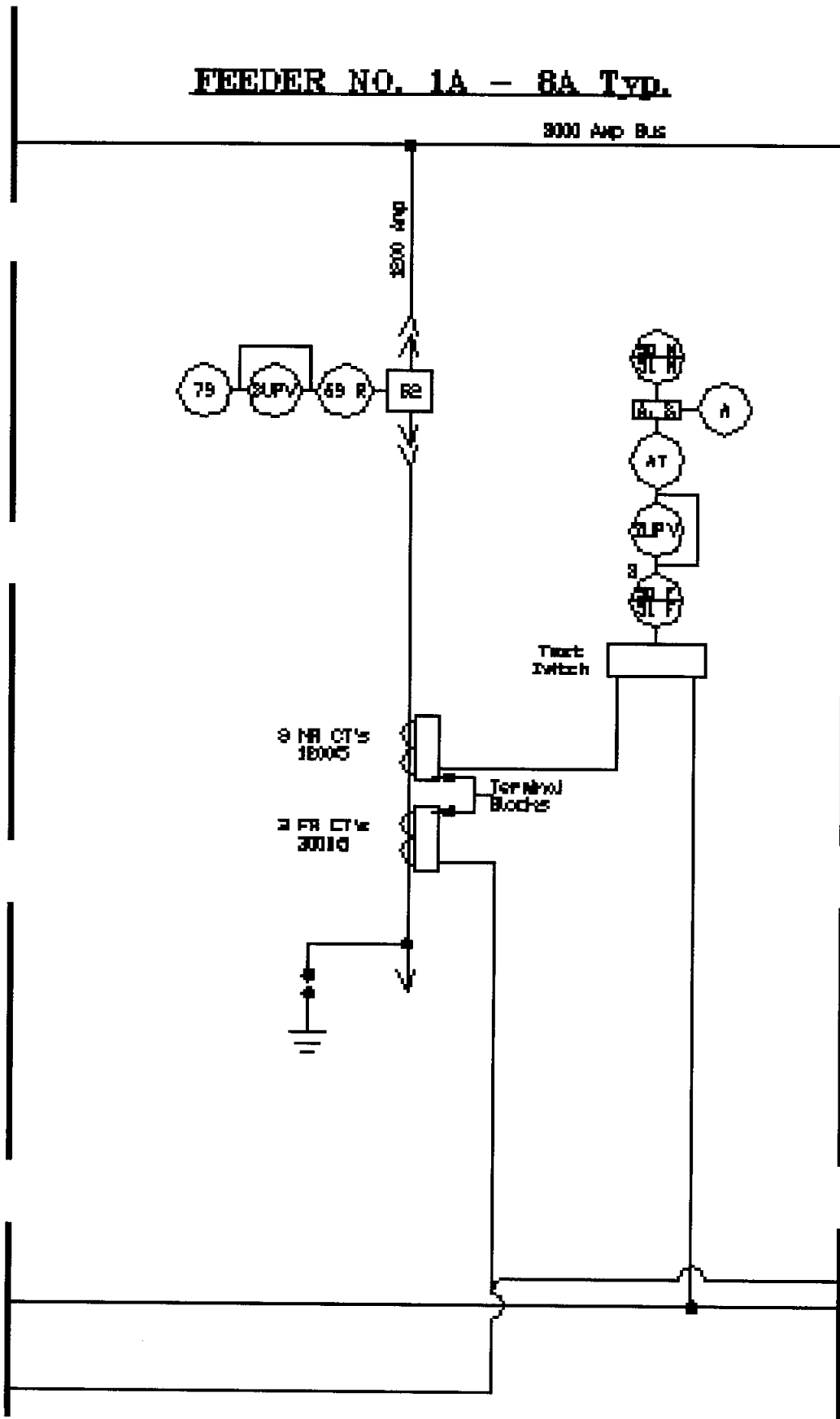

TIE BREAKER

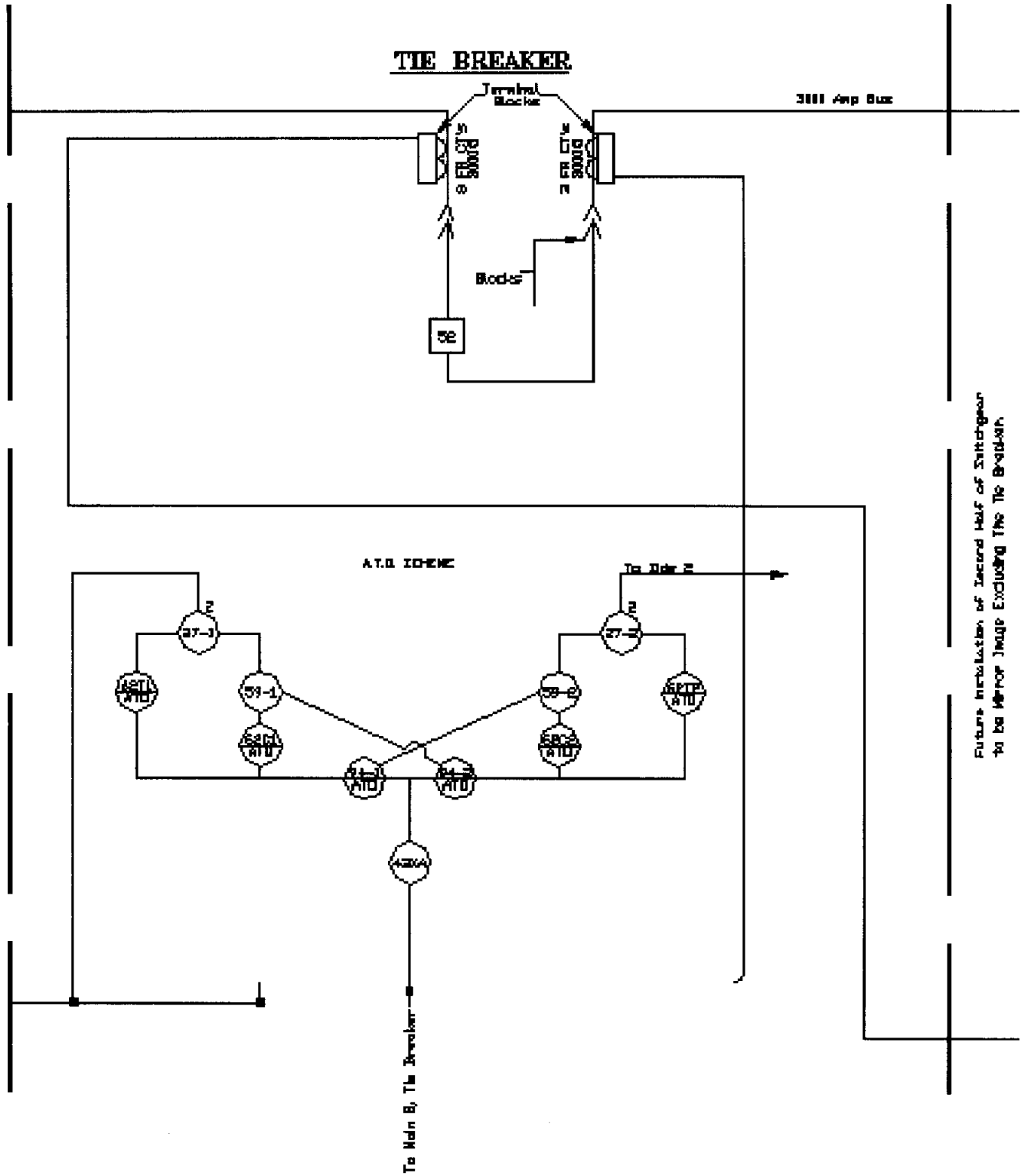

Future installation of second half of Switchgear
to be Mirror Image Excluding Tie Breaker.

AUXILIARY

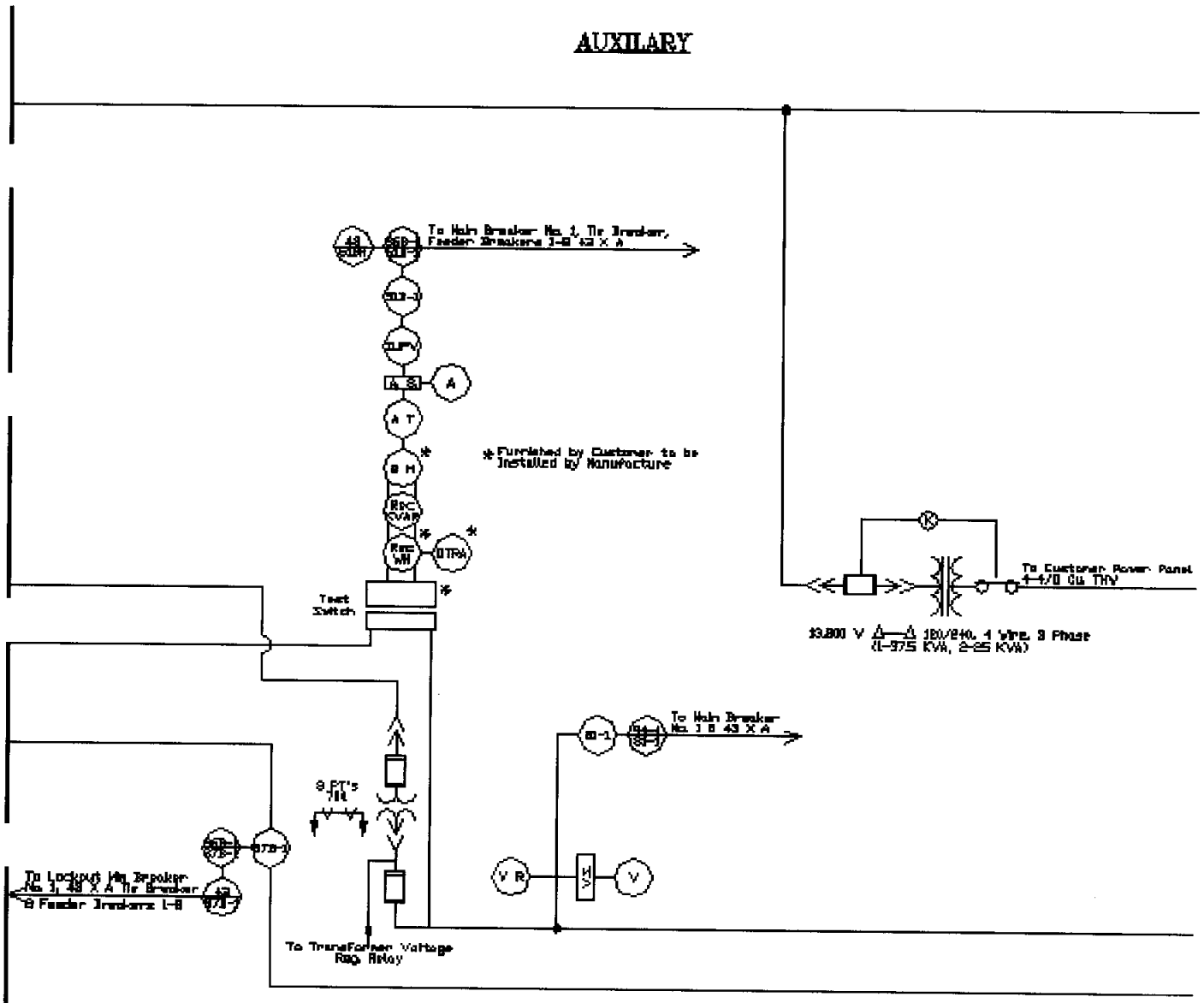

BREAKER 1

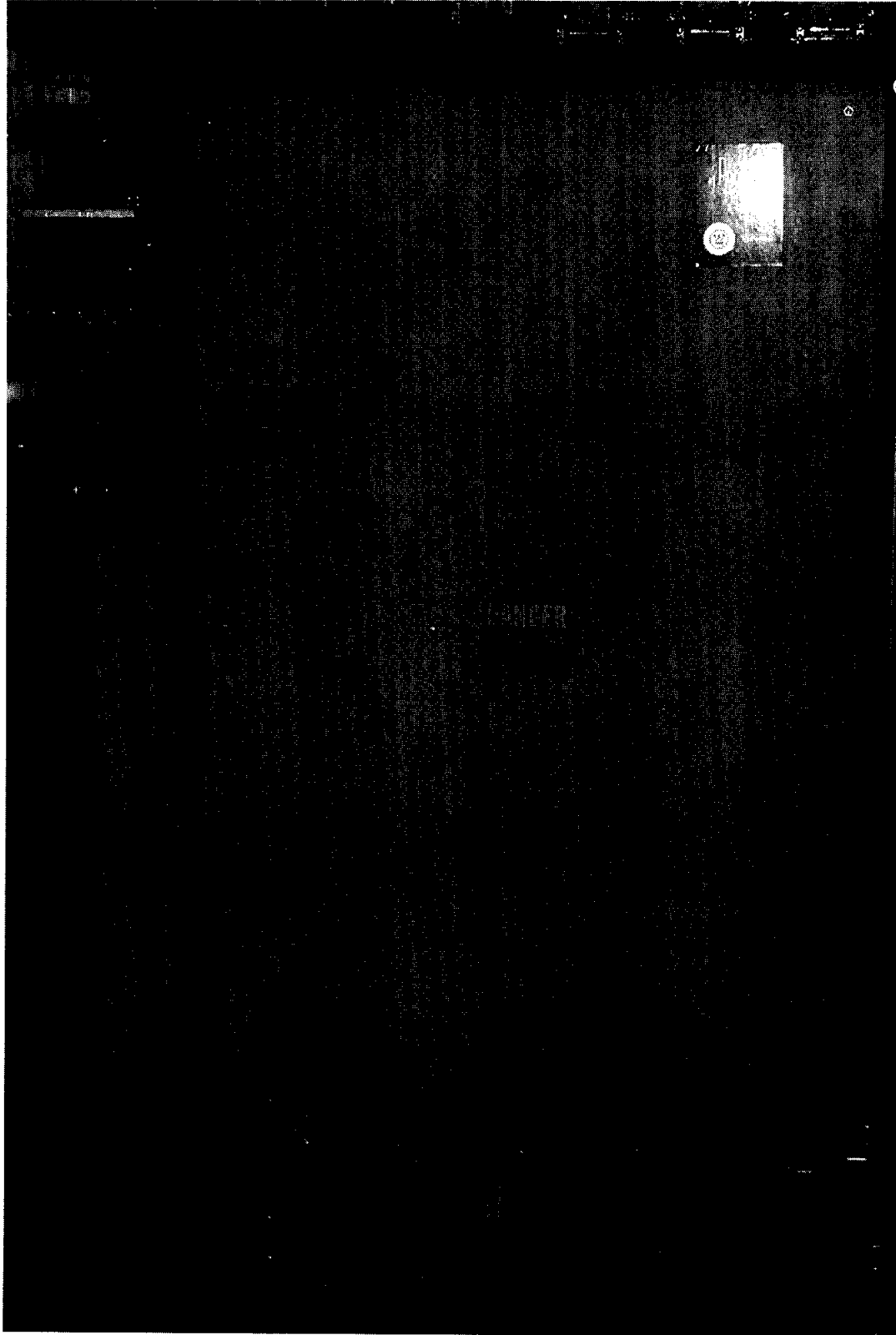

BREAKER 2

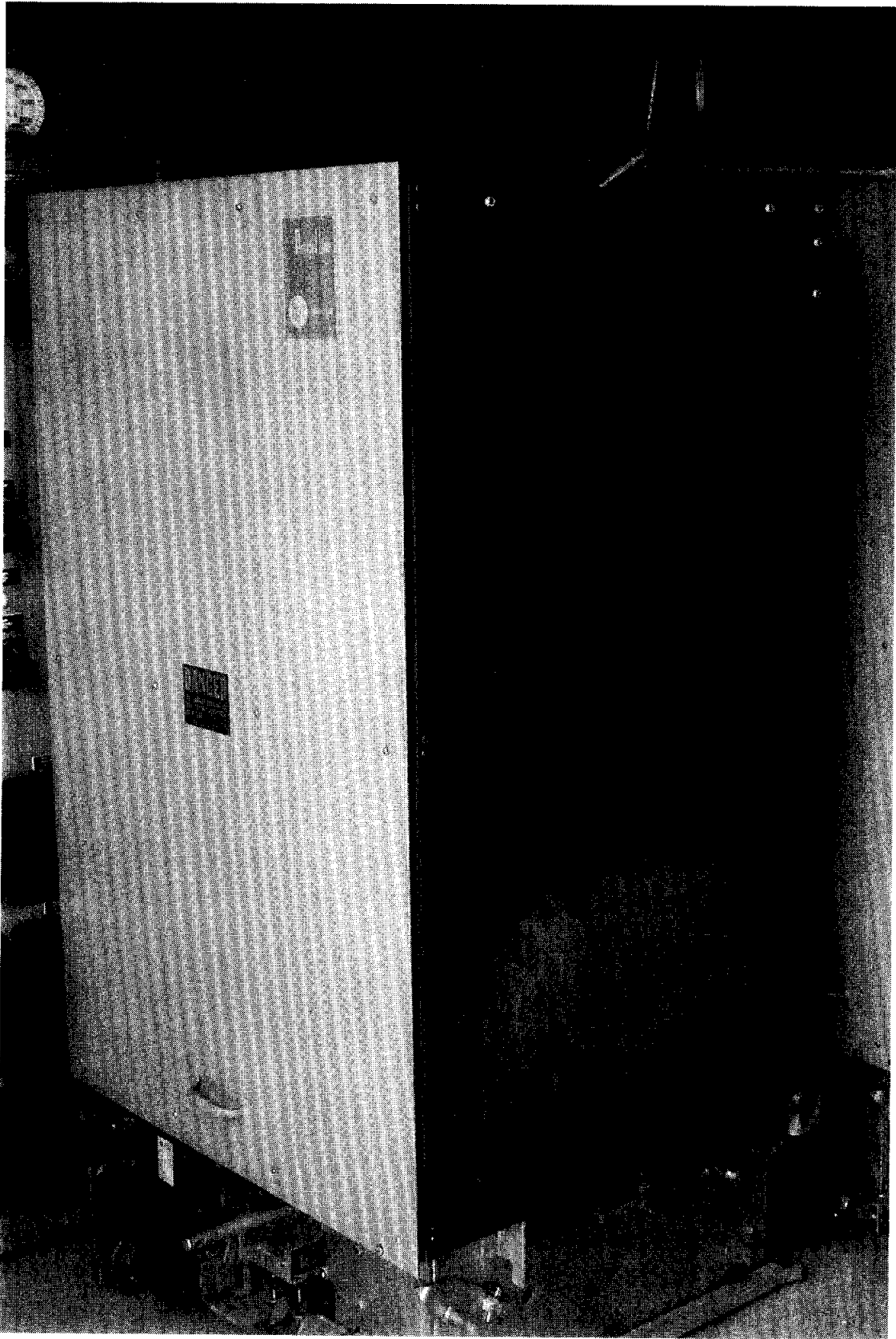

GROUNDING BREAKER 1

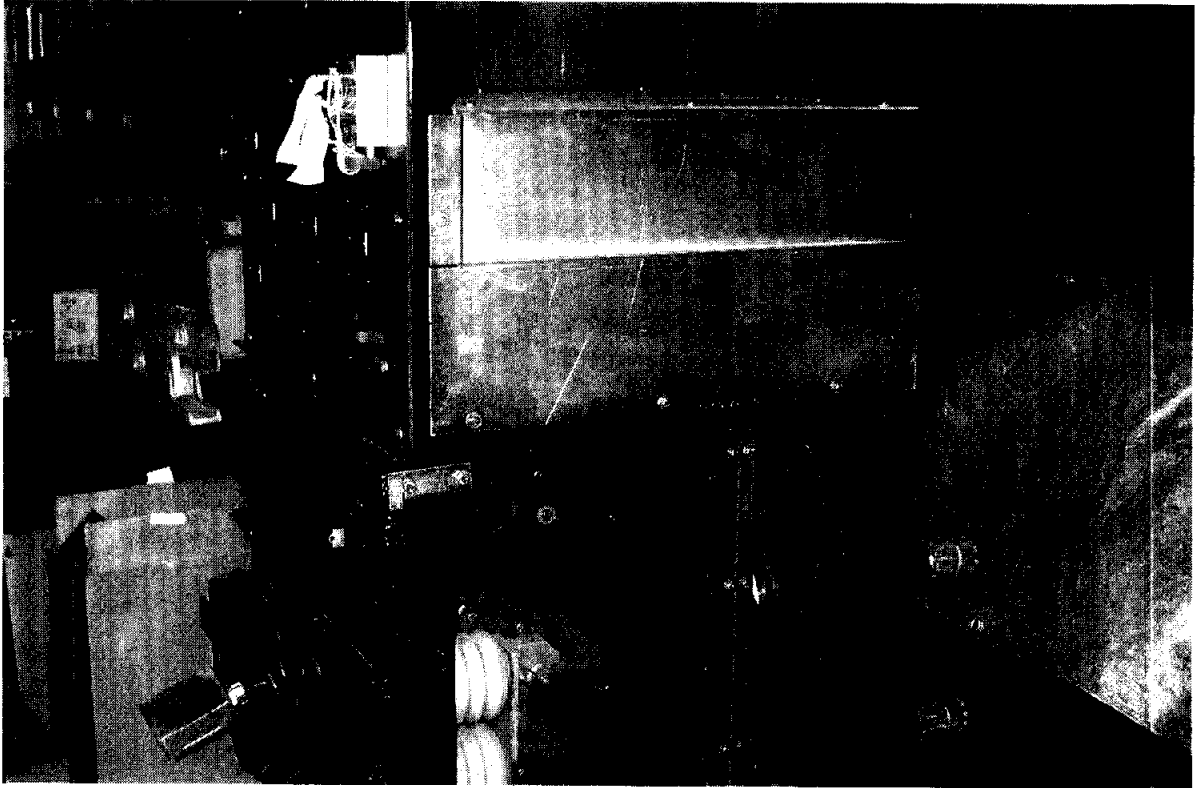

SWITCHGEAR 1

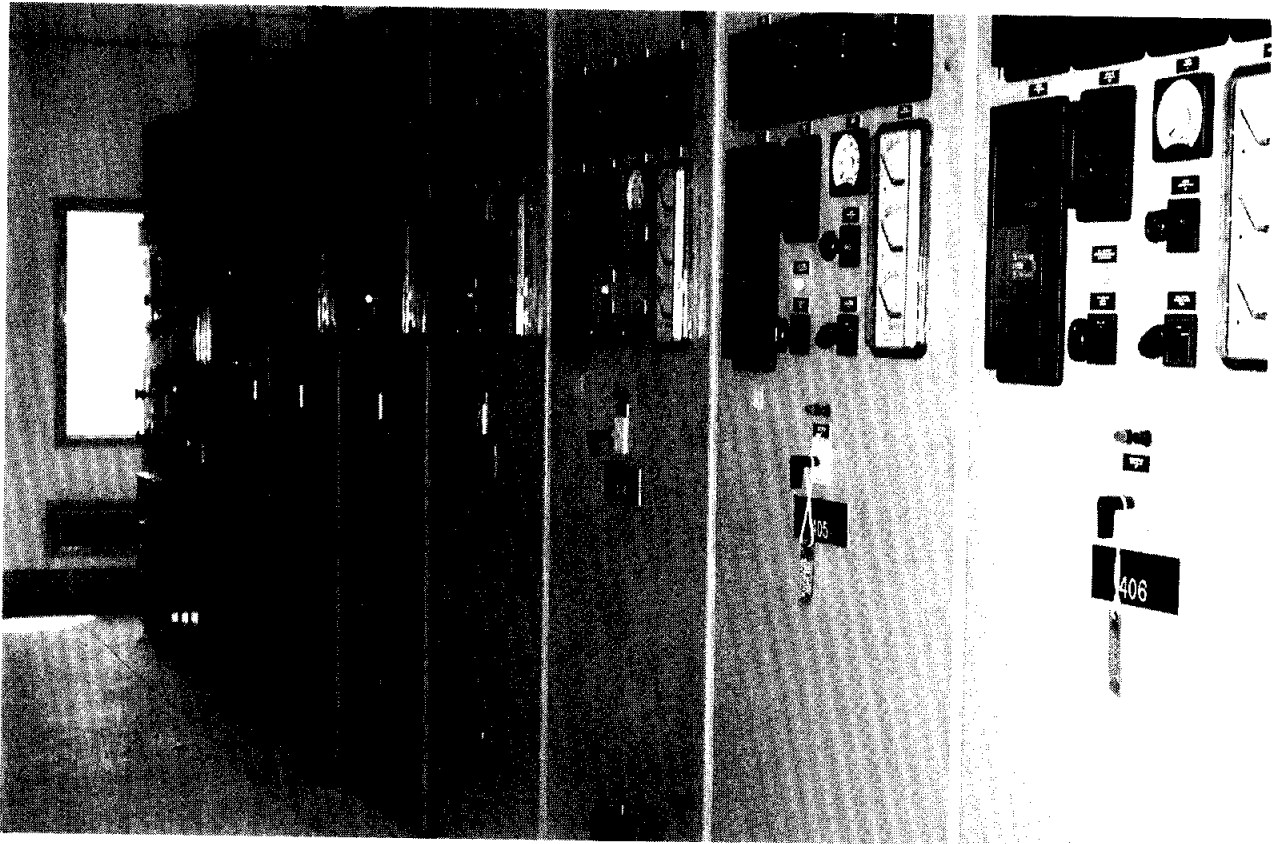

SWITCHGEAR 2

