



Administrative Services
Purchasing Division

INVITATION TO BID
BID #5765
L&P Transformer Pad & Sleeve

Sealed bids will be received and publicly opened at the office of the Director Of Purchasing and Risk Management, PO Box 580, 215 North Mason St., 2nd floor, Fort Collins, Colorado 80521, at the time and date noted on the bid proposal and/or contract documents. If delivered, they are to be delivered to 215 North Mason Street, 2nd Floor, Fort Collins, Colorado 80521. If mailed, the address is P.O. Box 580, Fort Collins, 80522-0580.

Bids must be received at the Purchasing Office prior to 2:00p.m. (our clock), Feb. 7, 2003.

Special Instructions

All bids must be properly signed by an authorized representative of the company with the legal capacity to bind the company to the agreement. Bids may be withdrawn up to the date and hour set for closing. Once bids have been accepted by the City and closing has occurred, failure to enter into contract or honor the purchase order will be cause for removal of supplier's name from the City of Fort Collins' bidders list for a period of twelve months from the date of the opening. The City may also pursue any remedies available at law or in equity. Bid prices must be held firm for a period of forty-five (45) days after bid openings.

Submission of a bid is deemed as acceptance of all terms, conditions and specifications contained in the City's specifications initially provided to the bidder. Any proposed modification must be accepted in writing by the City prior to award of the bid.

Only bids properly received by the Purchasing Office will be accepted. All bids should be clearly identified by the bid number and bid name contained in the bid proposal.

No proposal will be accepted from, or any purchase order awarded, to any person, firm or corporation in default on any obligation to the City.

Bids must be furnished exclusive of any federal excise tax, wherever applicable.

Bidders must be properly licensed and secure necessary permits wherever applicable.

Bidders not responding to this bid will be removed from our automated vendor listing for the subject commodities.

The City may elect where applicable, to award bids on an individual item/group basis or on a total bid basis, whichever is most beneficial to the City. The City reserves the right to accept or reject any and all bids, and to waive any irregularities or informalities.

Sales prohibited/conflict of interest: No officer, employee, or member of City Council, shall have a financial interest in the sale to the City of any real or personal property, equipment, material, supplies or services where such officer or employee exercises directly or indirectly any decision-making authority concerning such sale or any supervisory authority over the services to be rendered. This rule also applies to subcontracts with the City. Soliciting or

accepting any gift, gratuity, favor, entertainment, kickback or any items of monetary value from any person who has or is seeking to do business with the City of Fort Collins is prohibited.

Freight terms: Unless otherwise noted, all freight is F.O.B. Destination, Freight Prepaid. All freight charges must be included in prices submitted on proposal.

Discounts: Any discounts allowed for prompt payment, etc., must be reflected in bid figures and not entered as separate pricing on the proposal form.

Purchasing restrictions: Your authorized signature of this bid assures your firm's compliance with the City's purchasing restrictions. A copy of the resolutions is available for review in the Purchasing Office or the City Clerk's Office. Request Resolution 91-121 for cement restrictions.

Collusive or sham bids: Any bid deemed to be collusive or a sham bid will be rejected and reported to authorities as such. Your authorized signature of this bid assures that such bid is genuine and is not a collusive or sham bid.

Bid results: For information regarding results for individual bids send a self-addressed, self-stamped envelope and a bid tally will be mailed to you. Bid results will be posted in our office 7 days after the bid opening.



James B. O'Neill II, CPPO, FNIGP
Director of Purchasing and Risk Management

FIRM NAME: _____

CITY OF FORT COLLINS

BID PROPOSAL

BID NO. 5765

BID OPENING: February 7, 2003 (our clock) 2:00 p.m.

WE HEREBY ENTER OUR BID FOR THE CITY OF FORT COLLINS' REQUIREMENTS FOR LP Transformer Pad & Sleeve PER THE BID INVITATION AND ANY REFERENCED SPECIFICATIONS.

QUANTITY: _____ DESCRIPTION:

75 Ea. Transformer pad, for single phase transformer, 48" x 46" x 3" polymer concrete with 15" x 24" opening centered 6" from front of pad, for use w/Quazite sleeve #LE2436B501. Per Spec. Drawing #368-600, Serial 01, Rev. A. Quazite #PH4846Z500, Component Part No. H4846B500.

\$ _____ Ea. \$ _____ Total

Mfr. _____ Mfr. # _____

Delivery in weeks: _____

75 Ea. Transformer sleeve, for single phase transformer installation, 24" x 36" x 18" light weight polymer concrete with 2 floating nuts at opposite corners for bolting to pad, including 2 hold-down bolts, 3/8" x 8" min. length, with 3" UNC thread, (special-Quazite #80061), Per Spec. Drawing #368-600, Serial 02, Rev. A. Quazite #PH4846Z500, Component Part No. LE2436B501.

NOTE: THE HOLD DOWN BOLTS NEED TO HAVE THE 3" UNC THREAD OR THEY WILL BE RETURNED TO MANUFACTURER FOR THE CORRECT BOLT.

\$ _____ Ea. \$ _____ Total

Mfr. _____ Mfr. # _____

Delivery in weeks: _____

Items being bid meet the above specifications without exception. Yes ___ No ___. If not, please list exceptions, specifying paragraph reference number, on a separate sheet and attach to your bid.

For purposes of warranty and service ONLY approved manufacturers or distributors authorized by an approved manufacturer to serve the Fort Collins area may bid.

Bid #5765

SUPPLEMENTAL INSTRUCTIONS

Prices quoted must remain firm for a 30 day period after the opening date.

Freight terms: F.O.B. destination freight prepaid. All freight charges must be included in pricing submitted on proposal and not entered as separate pricing.

Any discount allowed by Vendor for prompt payment, etc. must be reflected in quoted figure, and not entered as separate pricing.

The City reserves the right to accept or reject any and all quotes.

Bidder not responding to the services requested in this bid shall be removed from our automated listing for: Not Applicable

Any questions or inquiries regarding this bid should be directed to:

Opal F. Dick, CPPO, Senior Buyer (970) 221-6778

SIGNATURE AND TITLE _____

TYPED OR PRINTED NAME AND TITLE _____

COMPANY NAME _____

(AREA CODE) TELEPHONE NUMBER/FAX NUMBER _____

DRESS: STREET, CITY, STATE, ZIP _____

DATE _____

AD

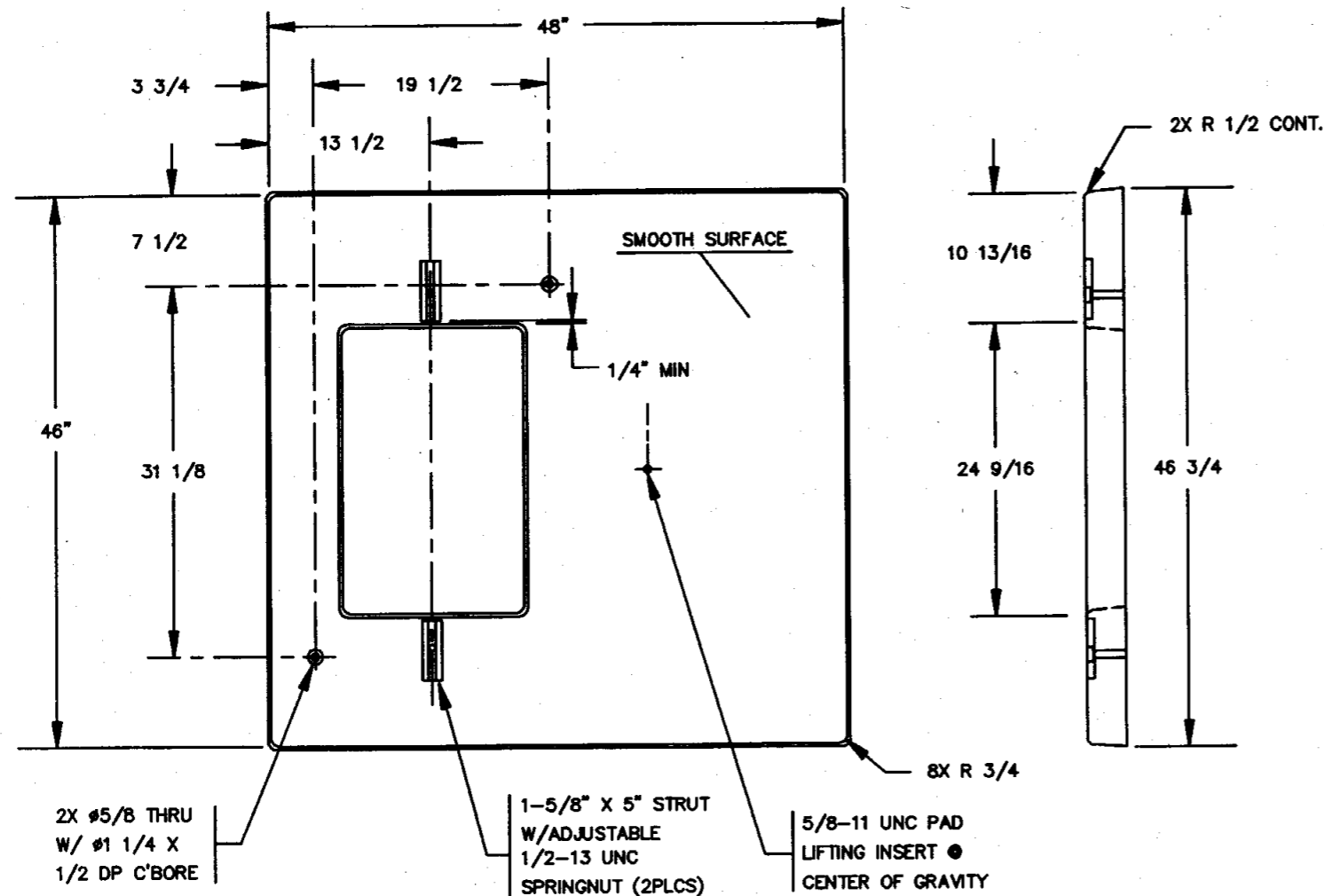

SERIAL NO. 1
Quazite PH4846B500

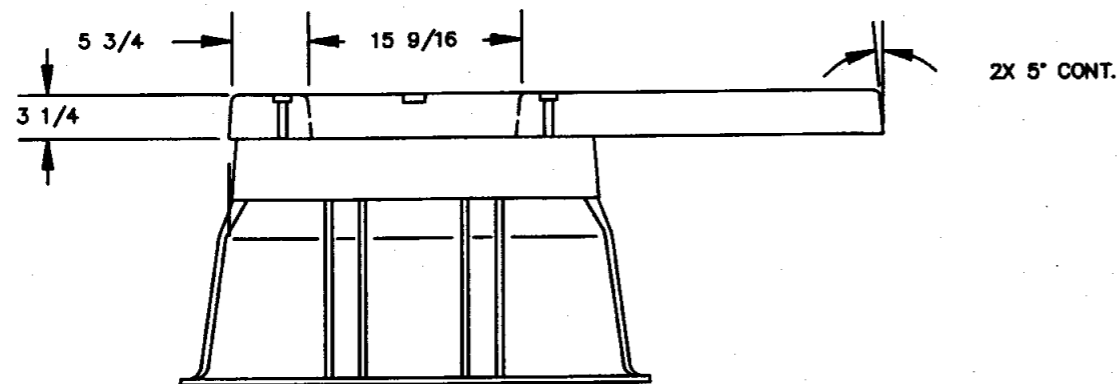

ASSEMBLY
Quazite PH4846Z500

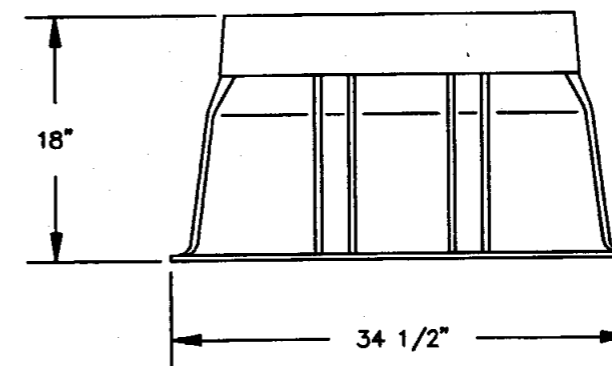
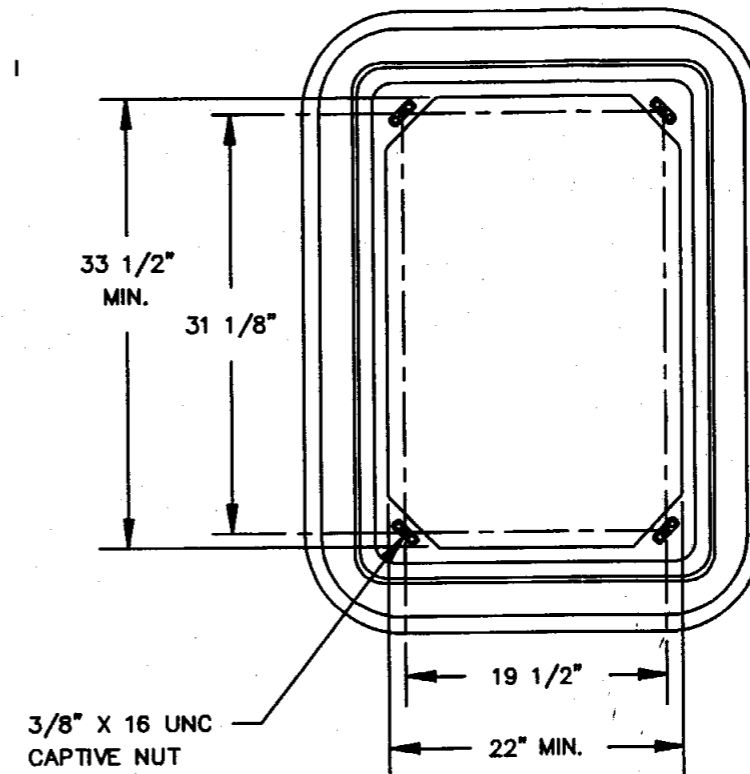

SERIAL NO. 2
Quazite LE2436B501

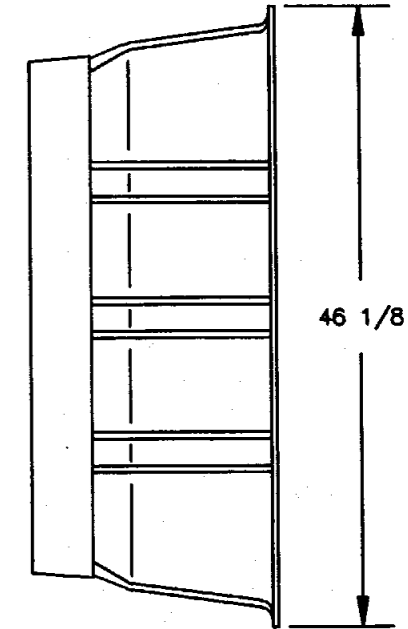

NOTES:

- 2 HOLD-DOWN BOLTS 3/8" X 8" X 16 UNC, MIN. 3" THREAD & 3/8" FLAT WASHERS SHALL BE PROVIDED WITH EACH SLEEVE.
- OVERALL EXTERIOR AND THROAT DIMENSIONS ARE ± 1/4"

A.	Add Serial #'s and dimensions on bolts	SC	3/20/94
REV.	DESCRIPTION	BY	APP'D DATE
TITLE POLYMER CONCRETE TRANSFORMER PAD & SLEEVE SPECIFICATION DRAWING #368-600			
PROJ. ENG.	APP'D BY		
T. SAGEN	<i>[Signature]</i>		
DRAWN BY	SCALE		
S. CORAM	none		
DATE	DRAWING NUMBER		
4/8/94	W.O. NUMBER	SUB	SHEET OF