

# PLAT OF ARTHUR SUBDIVISION

SITUATE IN THE NORTHWEST 1/4 OF SECTION 24,  
TOWNSHIP 7 NORTH, RANGE 69 WEST OF THE SIXTH  
P.M., FORT COLLINS, COLORADO

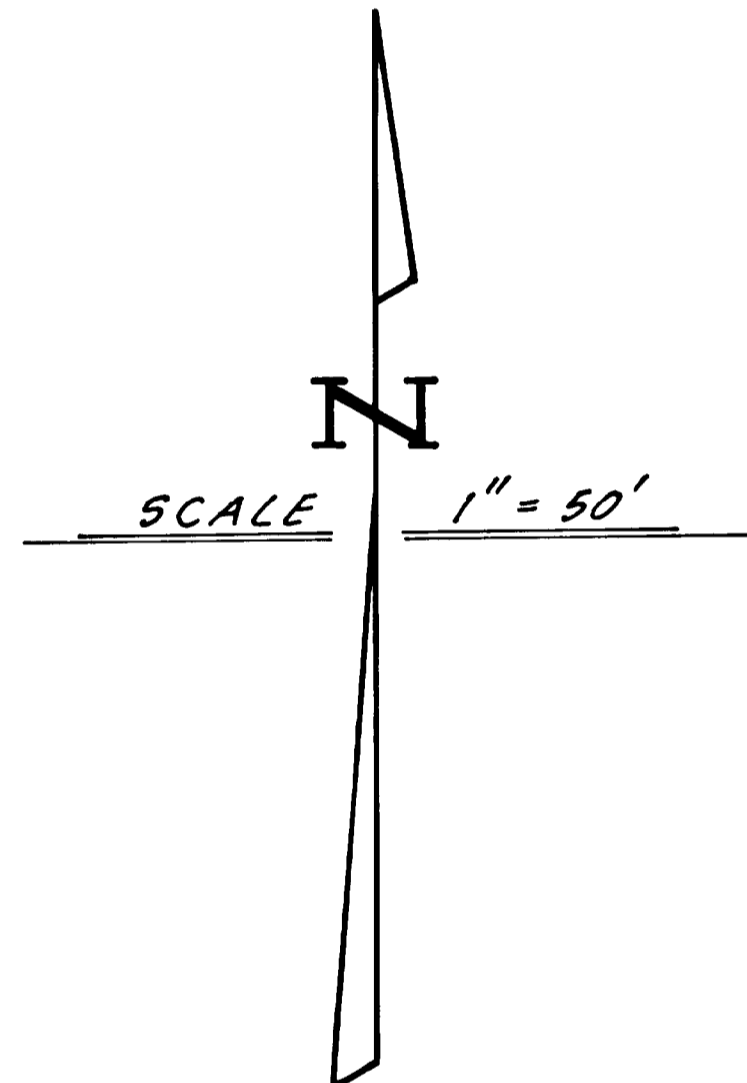
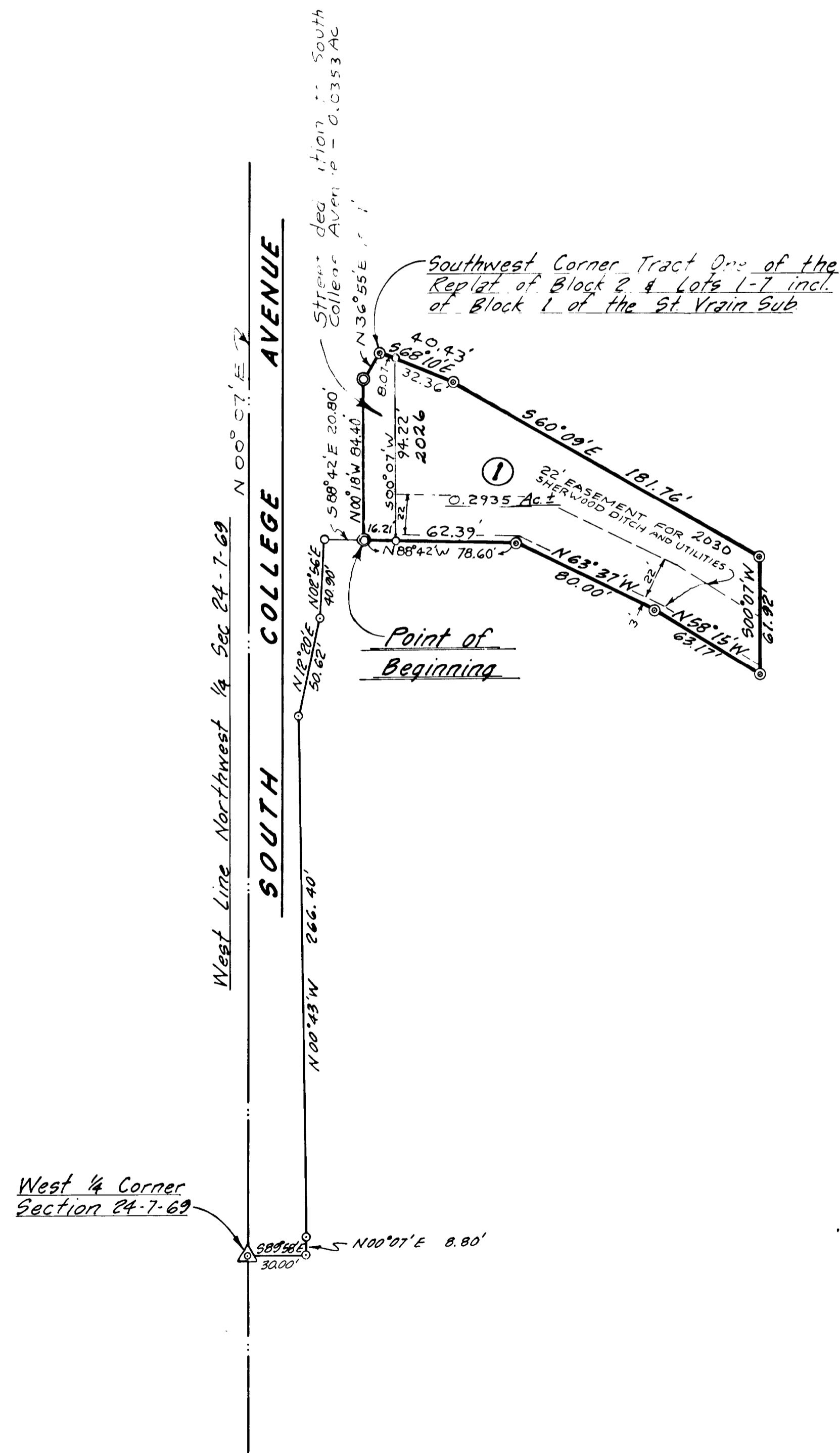

### STATEMENT OF OWNERSHIP, SUBDIVISION AND DEDICATION:

KNOW ALL MEN BY THESE PRESENTS: That the undersigned, being the owners of the following described tract of land, to-wit: A tract of land situate in the Northwest 1/4 of Section 24, Township 7 North, Range 69 West of the Sixth Principal Meridian, Fort Collins, Colorado, which, considering the West line of said Northwest 1/4 as bearing N00°07'E and with all bearings contained herein relative thereto, is contained within the boundary lines which begins at a point which bears S89°58'E 30.00 feet and again N00°07'E 8.80 feet and again N00°43'W 266.40 feet and again N12°20'E 50.62 feet and again N02°56'E 40.90 feet, and again S88°42'E 20.80 feet from the West 1/4 corner of said Section 24, and run thence N00°10'W 84.40 feet; thence N36°55'E 15.57 feet; thence S68°10'E 40.43 feet; thence S60°09'E 191.76 feet; thence S00°07'W 61.92 feet; thence N58°15'W 63.17 feet; thence N63°37'W 80.00 feet; thence N88°42'W 78.60 feet to the point of beginning, containing 0.3288 acres more or less, have caused the same to be surveyed and subdivided into a lot as shown on this plat to be known as the ARTHUR SUBDIVISION, and do hereby dedicate and convey, to and for public use, forever hereafter, the streets and easements as are laid out and designated on this plat.

Witness our hands and seals this 13th day of January, A.D. 1974.

Mae A. Tiley

K. Bill Tiley

State of Colorado } ss  
County of Larimer }

The foregoing instrument was acknowledged before me this 13th day of January, A.D. 1974 by Mae A. Tiley and K. Bill Tiley.

My notarial commission expires 12/31/74

Notary Public

### ENGINEER'S CERTIFICATE:

Richard A. Rutherford, a Professional Engineer and Land Surveyor under the laws of the State of Colorado, being first duly sworn on his oath, deposes and says that the survey and plat of the ARTHUR SUBDIVISION were under his supervision, that said plat is an accurate depiction of said survey, that he has read the statements thereon, and that the same are true to his own knowledge.

Richard A. Rutherford  
Professional Engineer & Land Surveyor

Subscribed and sworn to before me this 13th day of January, A.D. 1974.

Judy J. Junk  
Notary Public

### APPROVED:

By the Planning and Zoning Board of the City of Fort Collins, Colorado this 4th day of February, A.D. 1974.

The G. Rodenbeck  
Chairman

### APPROVED:

By the City Council of the City of Fort Collins, Colorado this 1st day of March, A.D. 1974.

Verma Lewis  
City Clerk