

FAX



TO: ED Bonnette
 COMPANY: Ft. Collins
 FAX #: 970-221-6707

6240 W. 54th Ave. • Arvada, CO 80002

(Remittance address remains the same: Dept. 450 Denver, CO 80291-0450)

FROM: Tracey Darley
 DATE: 2/18/03 TIME: 10:00
 # PAGES 12 (INCLUDING COVER)

New Phone Numbers:
 Sales and Corporate Office 303-539-3400
 Rental and Staging Division 303-539-3500

Have you seen [WWW.CEAVCO.COM](http://www.ceavco.com) ?

MESSAGE:

Utilities training room bid.
 Freight included as long as it is
 UPS Ground or FedEx Gaver.

Call w/ questions!

Tracey Darley
 303-539-3415



Administrative Services
Purchasing Division

Post-it® Fax Note	7671	Date	2/12/03	# of pages	6
To	TRACEY DALEY	From	ED BONNETTE		
Co./Dept	CEANCO A-V	Co.	FT-COLLINS PURCH		
Phone #		Phone	970-416-2247		
Fax #	303-539-3401	Fax	970-221-6707		

Date: February 12, 2003

Ref #: Utilities Training Room

THIS IS A PRICE QUOTATION -- NOT AN ORDER

Please supply pricing and delivery information, all items to be quoted FOB Fort Collins, Colorado, as requested below; and respond via FAX BY Tuesday Feb 18, 2003 3:00 p.m. to:

Ed Bonnette, C.P.M.
(970) 221-6707

Any questions regarding this inquiry should be directed to Ed Bonnette, (970) 416-2247. Please refer technical questions to Merv Perkins (Display Devices) @ 303-882-1805.

BIDDING GUIDELINES:

The City has indicated a Preferred Brand for each item listed on the bid. The bidder may elect to offer an "or equivalent" brand as an option. The City will be the final judge as to whether the "equivalent" brand is acceptable in lieu of the Preferred brand requested.

The City reserves the right to make awards on a Line Item basis or on a Total Bid basis; whichever is most beneficial to the City.

All bids must include freight F.O.B. Destination, Freight Prepaid. All freight charges must be included in prices submitted on proposal.

Lead time for delivery must be indicated for all items. The City reserves the right to consider Delivery Date as a basis for award of this quotation. Equipment needs to be installed in Fort Collins (by a third-party installer, already under contract to the City) April 1-15, 2003.

QUANTITY:

1 each

DESCRIPTION:

Marshall Furniture Custom Podium, Drawing #10445

\$ 3,175 + 275 freight Ea. \$ 3,450⁰⁰ Total

Mfr. Marshall

Mfr. # MOP-52/#10445

Delivery: 4-6 weeks

Items being bid meet the above specifications without exception.
Yes No If not, please list exceptions, specifying paragraph reference number, on a separate sheet and attach to your bid.

See drawing

p. 1 of 6

QUANTITY:

1 each

DESCRIPTION:

Extron 5CR Switcher/system controller

\$ 1,775⁰⁰ Ea. \$ 1,775⁰⁰ Total
 Mfr. Extron Mfr. # 60-269-02

Delivery: 2 weeks

Items being bid meet the above specifications without exception.
 Yes No . If not, please list exceptions, specifying paragraph reference number, on a separate sheet and attach to your bid.

QUANTITY:

1 each

DESCRIPTION:

Extron RGB440 60-268-01 VGA to RGBHV Interface with audio buffering

\$ 490⁰⁰ Ea. \$ 490⁰⁰ Total
 Mfr. Extron Mfr. # 60-28-01

Delivery: 2 weeks

Items being bid meet the above specifications without exception.
 Yes No . If not, please list exceptions, specifying paragraph reference number, on a separate sheet and attach to your bid.

p. 2 of 6

QUANTITY:

1 each

DESCRIPTION:

Extron 26-502-02-LBC 90 VGA HR 6' cable

\$ 90⁰⁰ Ea. \$ 90⁰⁰ Total

Mfr. Extron Mfr. # 60-502-02

Delivery: 2 weeks

Items being bid meet the above specifications without exception.
Yes No . If not, please list exceptions, specifying paragraph reference number, on a separate sheet

QUANTITY:

1 each

DESCRIPTION:

AMX AXCENT3-PRO Control System

\$ 1,345⁰⁰ Ea. \$ 1,345⁰⁰ Total

Mfr. AMX Mfr. # Axcnt 3 Pro

Delivery: 2-4 weeks

Items being bid meet the above specifications without exception.
Yes No . If not, please list exceptions, specifying paragraph reference number, on a separate sheet

QUANTITY:

1 each

DESCRIPTION:

AMX AXD-CV10 10.4" Touch Panel with Video Display (Black)

\$ 3,970⁰⁰ Ea. \$ 3,970⁰⁰ Total

Mfr. AMX Mfr. # AXD-CV10

Delivery: 2-4 weeks

Items being bid meet the above specifications without exception.
Yes No . If not, please list exceptions, specifying paragraph reference number, on a separate sheet

p. 3 of 6

QUANTITY:

1 each

DESCRIPTION:

Extron ADA2 300MX-1 in 2 out RGB HV DA Amplifier

\$ 855⁰⁰ Ea.

\$ 855⁰⁰ Total

Mfr. Extron

Mfr. # 60-230-02

Delivery: 2 weeks

Items being bid meet the above specifications without exception. Yes No . If not, please list exceptions, specifying paragraph reference number, on a separate sheet

QUANTITY:

1 each

DESCRIPTION:

~~TDA~~ Tascam M-243 Audio Mixer

TDA is manufacturer not Tascam

\$ 455 Ea.

\$ 455 Total

Mfr. TDA

Mfr. # M-243

Delivery: 2 weeks

Items being bid meet the above specifications without exception. Yes No . If not, please list exceptions, specifying paragraph reference number, on a separate sheet

QUANTITY:

1 each

DESCRIPTION:

RDL STM-2 Phantom Power Supply with line level out (includes 24V supply)

\$ 110 Ea.

\$ 110 Total

Mfr. RDL

Mfr. # STM-2

Delivery: 2 weeks

Items being bid meet the above specifications without exception. Yes No . If not, please list exceptions, specifying paragraph reference number, on a separate sheet

QUANTITY:

1 each

Please specify which monitor will be mounted. The R5H-4A accommodates up to 5RU. For items 6RU and larger cost is \$95⁰⁰ ea.

DESCRIPTION:

Middle Atlantic Rack Mount Kit for monitor

\$ 85⁰⁰ Ea. \$ 85⁰⁰ Total

Mfr. Middle Atlantic Mfr. # R5H-4A

Delivery: 2 weeks

Items being bid meet the above specifications without exception. Yes No . If not, please list exceptions, specifying paragraph reference number, on a separate sheet need to know monitor

QUANTITY:

1 each

Please specify which VCR will be mounted up to 5 rack units

DESCRIPTION:

Middle Atlantic Rack Mount Kit for VCR

\$ 85⁰⁰ Ea. \$ 85⁰⁰ Total

Mfr. Middle Atlantic Mfr. # R5H-4A

Delivery: 2 weeks

Items being bid meet the above specifications without exception. Yes No . If not, please list exceptions, specifying paragraph reference number, on a separate sheet Need to know VCR

QUANTITY:

2 each

DESCRIPTION:

Infinity Outrigger 8 ohm loud speakers

\$ 340 Ea. \$ 680 Total

Mfr. Infinity Mfr. # Outrigger

Delivery: 2 weeks

Items being bid meet the above specifications without exception. Yes No . If not, please list exceptions, specifying paragraph reference number, on a separate sheet

p. 5 of 6

no such model #.

QUANTITY:

1 each

DESCRIPTION:

Extron 26-614-02-LBC 90 right angle cable HR 6'

26-502-22 is an LBC90, 6ft. Right angle cable. Angled upwards.

\$ ~~88~~ ^{90^W} Ea.

\$ ~~88~~ ^{90^W} Total

Mfr. Extron

Mfr. # 26-502-22

Delivery: _____

Items being bid meet the above specifications without exception. Yes ___ No ___ . If not, please list exceptions, specifying paragraph reference number, on a separate sheet



Vendor Name: _____

CEAVCO Audio-Visual Company, Inc.
8240 W. 54th Ave. • Arvada, CO 80002
Sales 303-539-3400 • Fax: 303-539-3401
Rentals 303-539-3500 • Fax: 303-539-3501
SALES • SERVICE • RENTALS • TAPE

Address: _____

Telephone # _____

Respondent Name: Tracey Dailey
(Please Print)

By: Tracey Dailey
(Signature)



Administrative Services
Purchasing Division

Post-it® Fax Note 7671		Date 2/12/03	Pages 6
To	TRACEY DALEY	From	ED BONNETTE
Co./Dept.	CRANE A-V	Co.	FT-COLLINS ADMIN
Phone #		Phone	970-416-2247
Fax #	303-539-3401	Fax	970-221-6707

Addendum to Fax Quote – Utilities Training Room Equipment
Date 2/14/03

Please supply pricing and delivery information, all items to be quoted FOB Fort Collins, Colorado, as requested below; and respond via FAX BY Tuesday Feb 18, 2003 3:00 p.m. to:

Ed Bonnette, C.P.M.
(970) 221-6707

Any questions regarding this inquiry should be directed to Ed Bonnette, (970) 416-2247. Please refer technical questions to Merv Perkins (Display Devices) @ 303-882-1805.

BIDDING GUIDELINES:

The City has indicated a Preferred Brand for each item listed on the bid. The bidder may elect to offer an "or equivalent" brand as an option. The City will be the final judge as to whether the "equivalent" brand is acceptable in lieu of the Preferred brand requested.

The City reserves the right to make awards on a Line Item basis or on a Total Bid basis; whichever is most beneficial to the City.

All bids must include freight F.O.B. Destination, Freight Prepaid. All freight charges must be included in prices submitted on proposal.

Lead time for delivery must be indicated for all items. The City reserves the right to consider Delivery Date as a basis for award of this quotation. Equipment needs to be installed in Fort Collins (by a third-party installer, already under contract to the City) April 1-15, 2003.

To clarify our Fax Quote Request sent out on 2/13/03 (response due in by 3:00 p.m. Tuesday February 18); please add the following item:

QUANTITY:

1 each

DESCRIPTION:

Alesis RA-150 90 watt Audio Amplifier

\$ 162⁰⁰ Ea.

\$ 162⁰⁰ Total

Mfr: Alesis
Mfr: RA-150
Delivery 2 weeks

Items being bid meet the above specifications without exception. Yes No . If not, please list exceptions, specifying paragraph reference number, on a separate sheet

Vendor Name: _____

Address: _____

Telephone # _____

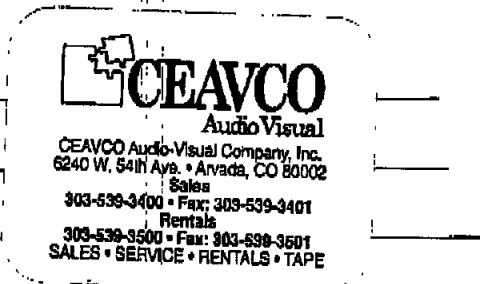

Respondent Name: Tracey Dailey
(Please Print)

By: Tracey Dailey
(Signature)

I hope this helps to clarify things for your bid. I am sorry for any confusion this may have caused. Please fax your responses to (970) 221-6707.

If any questions, please call me at (970) 416-2247.

Thanks You,

Ed Bonnette, C.P.M.
Buyer
City of Fort Collins, Colorado
Purchasing Division

Marshall Furniture Inc

MFI # 10445 JH Date: 1/6/02 Page# 1 of 3

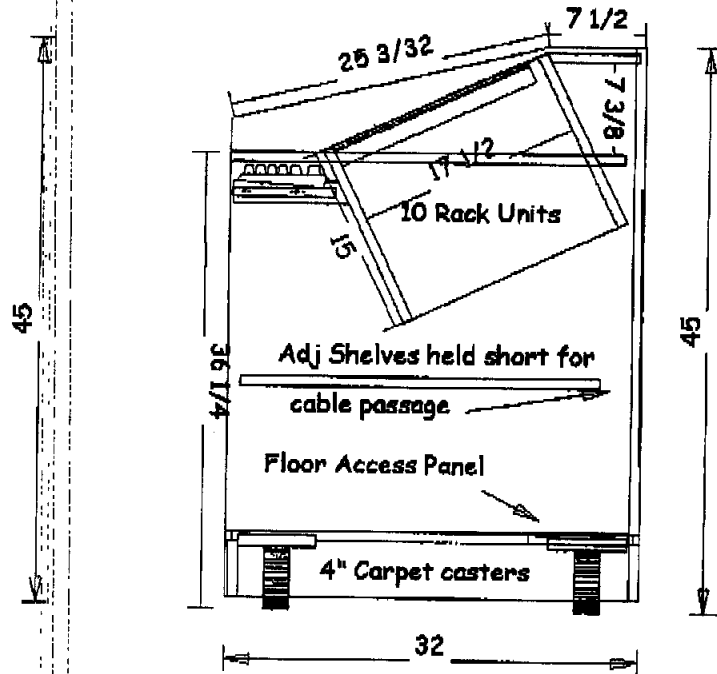
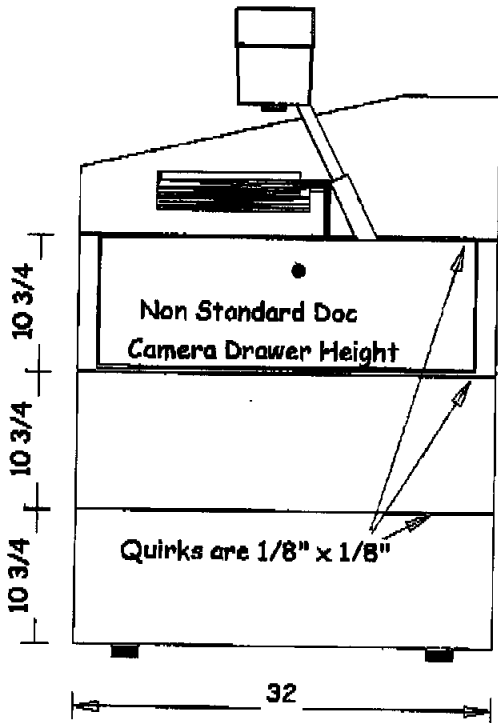
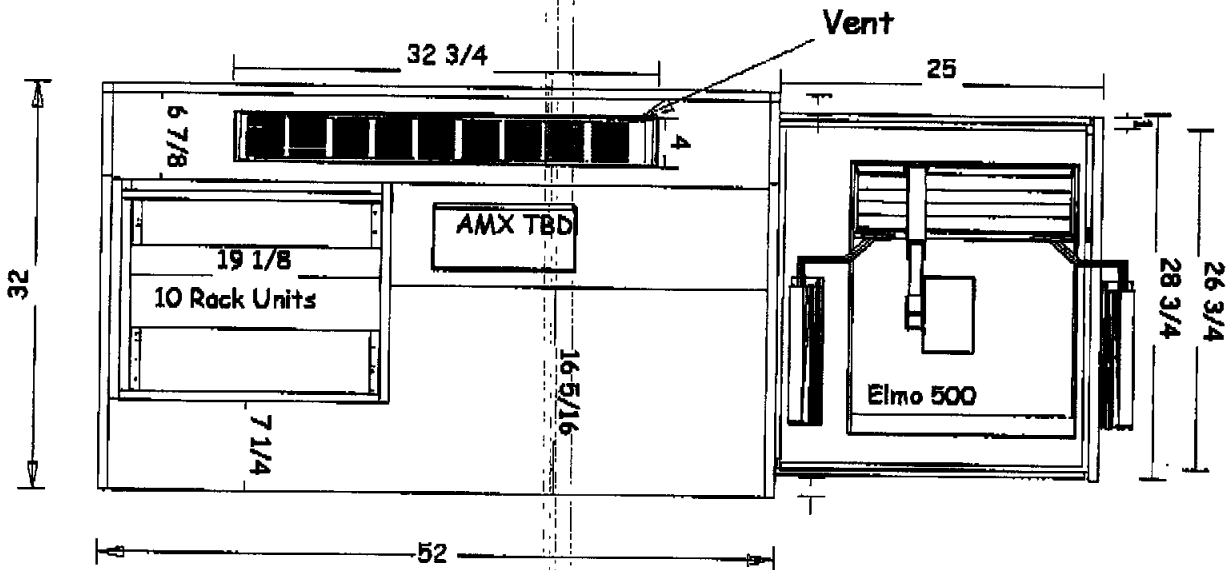

Check appropriate box.

Copyright 2000 By Marshall Furniture Inc. All Rights Reserved

<input type="checkbox"/> Ok for production	Signature	Date
<input type="checkbox"/> Ok for production with changes marked, do not resubmit		
<input type="checkbox"/> Resubmit drawings with changes marked.		

Marshall Furniture Inc, 999 Anita Ave, Antioch IL 60002
 Phone 847-395-9350, Fax 847-395-9351, www.marshallfurniture.com

Marshall Furniture Inc

MFI # 10445 JH Date: 1/6/02 Page# 2 of 3

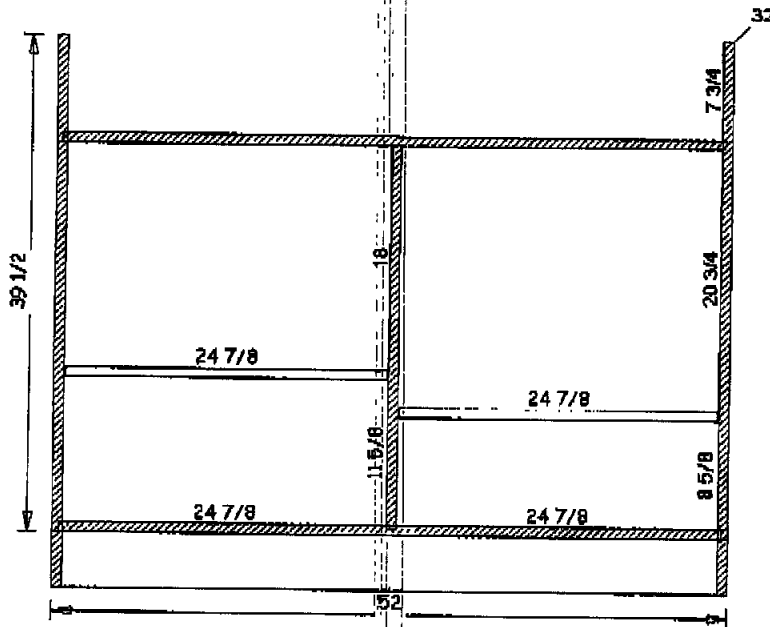
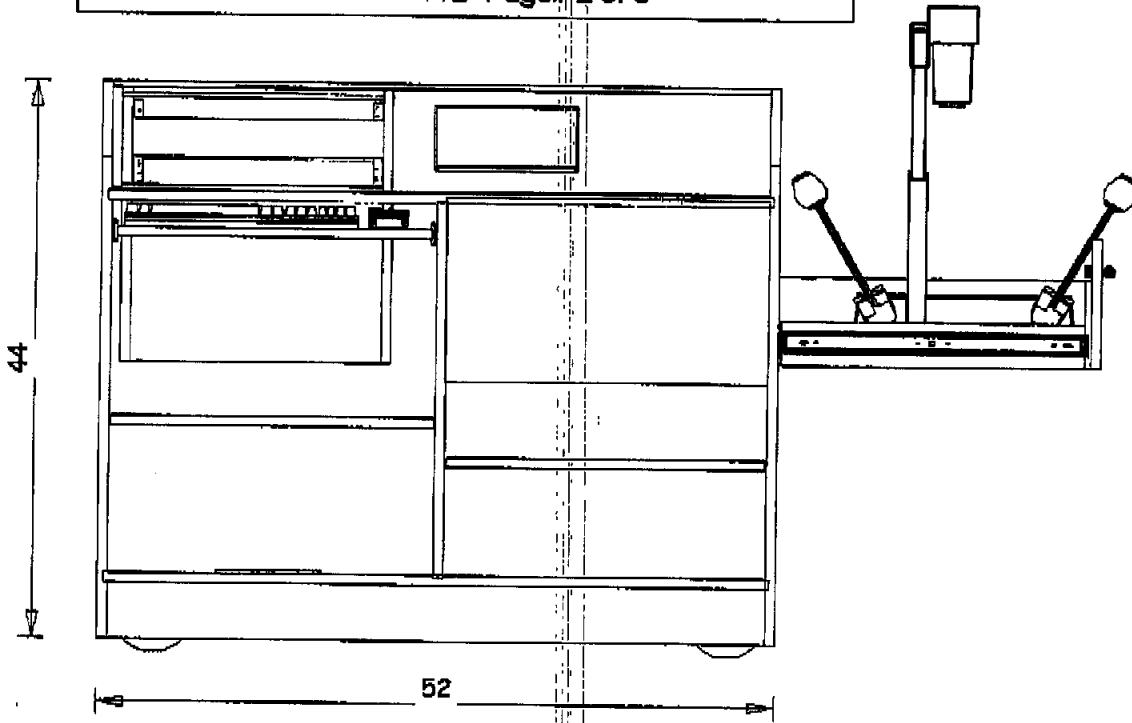

Check appropriate box

Copyright 2000 By Marshall Furniture Inc. All Rights Reserved

<input type="checkbox"/>	Ok for production	Signature	Date
<input type="checkbox"/>	Ok for production with changes marked, do not resubmit		
<input type="checkbox"/>	Resubmit drawings with changes marked.		
Marshall Furniture Inc, 999 Anita Ave, Antioch IL 60002 Phone 847-395-9350, Fax 847-395-9351, www.marshallfurniture.com			

Marshall Furniture Inc

MFI # 10445 JH Date: 1/6/02 Page# 3 of 3

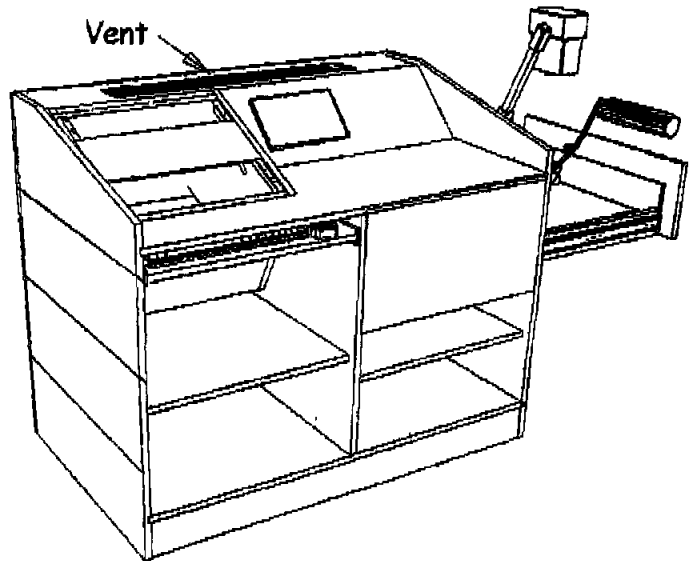
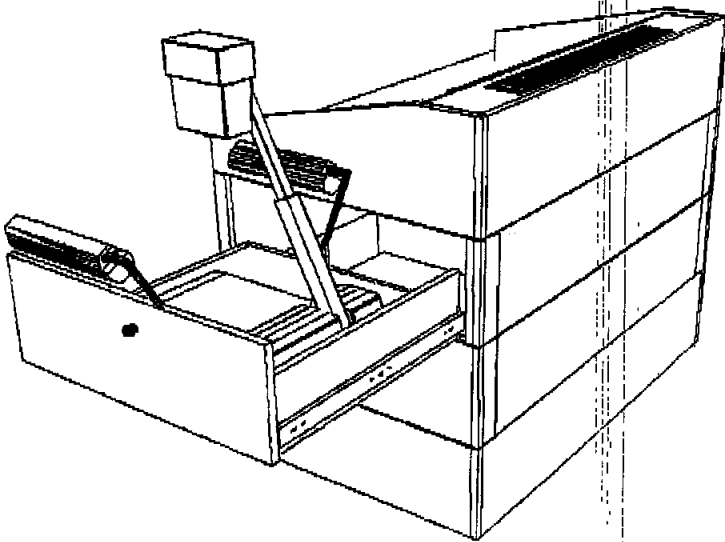
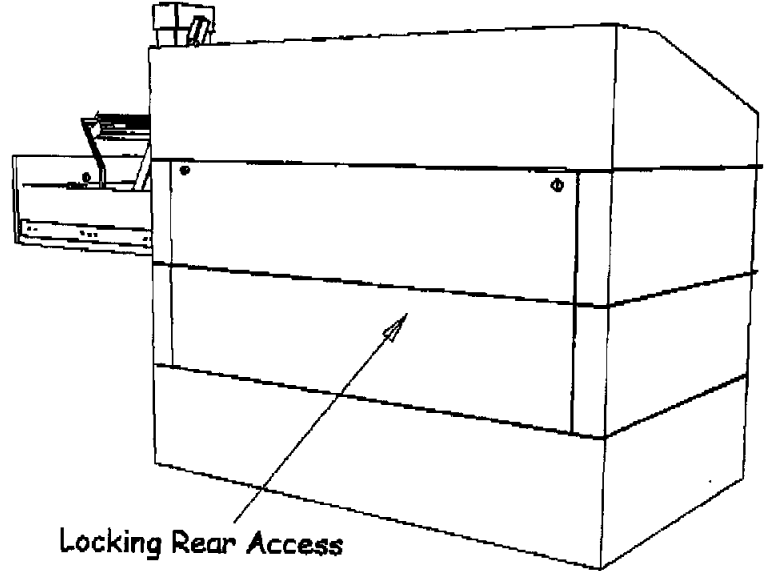
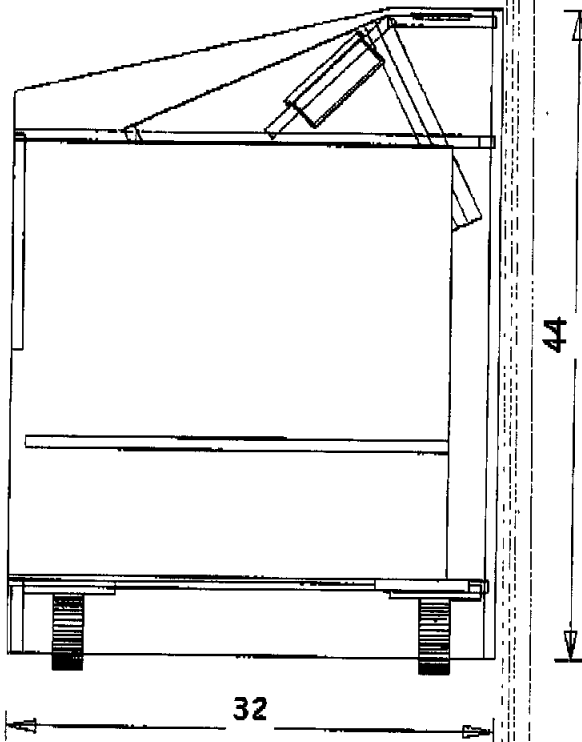

Check appropriate box.

Copyright 2000 By Marshall Furniture Inc. All Rights Reserved

<input type="checkbox"/> Ok for production	Signature	Date
<input type="checkbox"/> Ok for production with changes marked, do not resubmit		
<input type="checkbox"/> Resubmit drawings with changes marked.		

Marshall Furniture Inc, 999 Anita Ave, Antioch IL 60002
 Phone 847-395-9350, Fax 847-395-9351, www.marshallfurniture.com

fax



Media Consultants • Systems Integrators
373 Inverness Drive South
Suite 205
Phone 303-768-9580x240
fax 303-768-9956
Howard.Zucker@mcsinet.com

To: Ed Bonnette
Fax: 970-221-6707
Phone: 970-416-247
Re: Utilities Training Room Quote

From: Howard Zucker
Pages: 7
Date: 2/14/2003
CC: [Click here and type name]

• **Comments:**

Hello Ed,

I have included a quote for the Utilities Training room. Please let me know if you have questions.

Regards,

Howard Zucker
MCSI

This material is intended only for the individual or entity to which it is addressed. It may contain privileged or confidential information which is exempt from disclosure under applicable laws. If you are not the intended recipient, please note that you are strictly prohibited from disseminating or distributing this material (other than to intended recipient) or copying this material.

800.516.0600
www.mcsinet.com

Now your vision has a voice.™

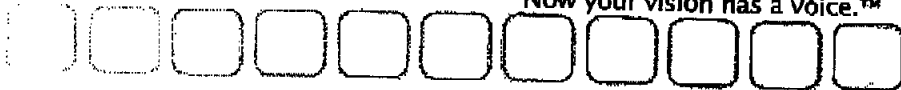

business solutions
control rooms
staging & rental
managed services
creative services
value-added resale
systems integration



Administrative Services
Purchasing Division

Post-It® Fax Note	7671	Date	2/12/03	# of Pages	6
To	MARIE BONNETT	From	ED BONNETTE		
Co./Dept.	MCSI	Co.	FT. COLLINS PURCH		
Phone #		Phone #	970-416-2247		
Fax #	303-768-9956	Fax #	970-221-6707		

Date: February 12, 2003
Ref #: Utilities Training Room

THIS IS A PRICE QUOTATION - NOT AN ORDER

Please supply pricing and delivery information, all items to be quoted FOB Fort Collins, Colorado, as requested below; and respond via FAX BY Tuesday Feb 18, 2003 3:00 p.m. to:

Ed Bonnette, C.P.M.
(970) 221-6707

Any questions regarding this inquiry should be directed to Ed Bonnette, (970) 416-2247. Please refer technical questions to Merv Perkins (Display Devices) @ 303-882-1805.

BIDDING GUIDELINES:

The City has indicated a Preferred Brand for each item listed on the bid. The bidder may elect to offer an "or equivalent" brand as an option. The City will be the final judge as to whether the "equivalent" brand is acceptable in lieu of the Preferred brand requested.

The City reserves the right to make awards on a Line Item basis or on a Total Bid basis; whichever is most beneficial to the City.

All bids must include freight F.O.B. Destination, Freight Prepaid. All freight charges must be included in prices submitted on proposal.

Lead time for delivery must be indicated for all items. The City reserves the right to consider Delivery Date as a basis for award of this quotation. Equipment needs to be installed in Fort Collins (by a third-party installer, already under contract to the City) April 1-15, 2003.

QUANTITY:

1 each

DESCRIPTION:

Marshall Furniture Custom Podium, Drawing #10445

\$ 3,555 Ea.

\$ 3,555 Total

Mfr. MARSHALL

Mfr. # #10445

Delivery: UPON AWARD OF CONTRACT 10-14 DAYS

Items being bid meet the above specifications without exception.
Yes No . If not, please list exceptions, specifying paragraph reference number, on a separate sheet and attach to your bid.

p. 1 of 6

QUANTITY:

1 each

DESCRIPTION:

Extron 5CR Switcher/system controller

\$ 1,937 Ea. \$ 1,937 Total

Mfr. Extron Mfr.# 60-269-02

Delivery: IN stock Ready ship upon Contract Award

Items being bid meet the above specifications without exception.
Yes No . If not, please list exceptions, specifying paragraph reference number, on a separate sheet and attach to your bid.

QUANTITY:

1 each

DESCRIPTION:

Extron RGB440 60-268-01 VGA to RGBHV Interface with audio buffering

\$ 535⁰⁰ Ea. \$ 535⁰⁰ Total

Mfr. Extron Mfr.# 60-268-01

Delivery: In stock Ready to ship upon Contract Award

Items being bid meet the above specifications without exception.
Yes No . If not, please list exceptions, specifying paragraph reference number, on a separate sheet and attach to your bid.

p. 2 of 6

QUANTITY:

1 each

DESCRIPTION:

Extron 26-502-02-LBC 90 VGA HR 6' cable

\$ 97⁰⁰ Ea. \$ 97⁰⁰ Total

Mfr. Extron Mfr.# 26-502-02

Delivery: IN stock to ship upon contract award

Items being bid meet the above specifications without exception.
Yes No If not, please list exceptions, specifying paragraph reference number, on a separate sheet

QUANTITY:

1 each

DESCRIPTION:

AMX AXCENT3-PRO Control System

\$ 1,119⁰⁰ Ea. \$ 1,119⁰⁰ Total

Mfr. AMX Mfr.# FG-5955-00

Delivery: IN stock to ship upon contract award

Items being bid meet the above specifications without exception.
Yes No If not, please list exceptions, specifying paragraph reference number, on a separate sheet

QUANTITY:

1 each

DESCRIPTION:

AMX AXD-CV10 10.4" Touch Panel with Video Display (Black)

\$ 4,444 Ea. \$ 4,444⁰⁰ Total

Mfr. AMX Mfr.# _____

Delivery: IN stock to ship upon contract award

Items being bid meet the above specifications without exception.
Yes No If not, please list exceptions, specifying paragraph reference number, on a separate sheet

p. 3 of 6

QUANTITY:

1 each

DESCRIPTION:

Extron ADA2 300MX-1 in 2 out RGB HV DA Amplifier

\$ 328⁰⁰ Ea. \$ 328⁰⁰ Total

Mfr. Extron Mfr. # 60-10302

Delivery: in stock to ship upon contract award

Items being bid meet the above specifications without exception.
Yes No If not, please list exceptions, specifying paragraph reference number, on a separate sheet

QUANTITY:

1 each

DESCRIPTION:

Tascam M-243 Audio Mixer

part # DOES NOT EXIST. N/A

\$ N/A Ea. \$ Total

Mfr. Mfr. #

Delivery:

Items being bid meet the above specifications without exception.
Yes No If not, please list exceptions, specifying paragraph reference number, on a separate sheet

QUANTITY:

1 each

DESCRIPTION:

RDL STM-2 Phantom Power Supply with line level out (includes 24V supply)

\$ 118⁰⁰ Ea. \$ 118⁰⁰ Total

Mfr. RDL Mfr. # STM-2

Delivery: in stock ready to ship upon contract award

Items being bid meet the above specifications without exception.
Yes No If not, please list exceptions, specifying paragraph reference number, on a separate sheet

p. 4 of 6

QUANTITY:

1 each

DESCRIPTION:

Middle Atlantic Rack Mount Kit for monitor

ML "

NEED MONITOR SIZE

\$ N/A Ea.

\$ _____ Total

Mfr. _____

Mfr.# _____

Delivery: _____

Items being bid meet the above specifications without exception. Yes ___ No X. If not, please list exceptions, specifying paragraph reference number, on a separate sheet

QUANTITY:

1 each

DESCRIPTION:

Middle Atlantic Rack Mount Kit for VCR

\$ 83⁰⁰ Ea.

\$ 83⁰⁰ Total

Mfr. Middle Atlantic

Mfr.# RSH4ARM

Delivery: in stock Ready to ship upon confirmed order

Items being bid meet the above specifications without exception. Yes ___ No ___ . If not, please list exceptions, specifying paragraph reference number, on a separate sheet

QUANTITY:

2 each

DESCRIPTION:

Infinity Outrigger 8 ohm loud speakers

\$ 180⁰⁰ Ea.

\$ 360⁰⁰ Total

Mfr. JBL

Mfr.# Contact 28"

Delivery: in stock

Items being bid meet the above specifications without exception. Yes ___ No X. If not, please list exceptions, specifying paragraph reference number, on a separate sheet

*MCSI DOES NOT CARRY INFINITY SPEAKERS
JBL option available*

p. 5 of 6

QUANTITY:

1 each

DESCRIPTION:

Extron 26-614-02-LBC 90 right angle cable HR 6'

\$ 97⁰⁰ Ea. \$ 97⁰⁰ Total

Mfr. Extron Mfr. # 26-502-02

Delivery: 14 stock ready to ship upon contract award

Items being bid meet the above specifications without exception.
Yes No . If not, please list exceptions, specifying paragraph reference number, on a separate sheet

Vendor Name: MCSI

Address: 373 Inverness Parkway, # 205, Englewood, CO

Telephone # 303-768-9580 FAX # 303-768-9956 80112

Respondent Name: Howard Zucker
(Please Print)

By: [Signature]
(Signature)



MCSI.
Media Consultants • Systems Integrators

Howard Zucker
Major Account Manager

373 Inverness Drive South
Suite 205
Englewood, CO 80112

Phone: (303) 768-9580
Ext. 240
Fax: (303) 768-9956

Howard.Zucker@mcsinet.com
www.mcsinet.com

p. 6 of 6

SPECTRUM AUDIO VISUAL
351 W. 45TH AVE.
DENVER, CO 80216
(303) 561-4241
(303) 477-3348 FAX

FACSIMILE TRANSMITTAL SHEET

TO: Ed Bonnette	FROM: Jamie Klym
COMPANY: City of Fort Collins	DATE:
FAX NUMBER: 970-221-6707	TOTAL NO. OF PAGES INCLUDING COVER:
PHONE NUMBER	SENDER'S REFERENCE NUMBER:
RE:	YOUR REFERENCE NUMBER:

URGENT FOR REVIEW PLEASE COMMENT PLEASE REPLY PLEASE RECYCLE

NOTES/COMMENTS:

Hi Ed,
Quoted only items we are dealers for. Please let me know if you have any questions or need additional information.

Thank you,

Jamie Klym
Spectrum Audio Visual
(303) 561-4241
jklym@indra.com

351 W 45TH AVE. DENVER, CO 80216



Administrative Services

Purchasing Division

Post-it® Fax Note	7671	Date	2/12/03	# of pages	6
To	JAMIE KLYM	From	ED BONNETTE		
Co./Dept	SPECTRUM A-V	Co.	FT. COLLINS PURCH		
Phone #		Phone #	970-416-2247		
Fax #	303-477-0114	Fax #	970-221-6707		

Date: February 12, 2003

Ref #: Utilities Training Room

THIS IS A PRICE QUOTATION – NOT AN ORDER

Please supply pricing and delivery information, all items to be quoted FOB Fort Collins, Colorado, as requested below; and respond via FAX BY Tuesday Feb 18, 2003 3:00 p.m. to:

Ed Bonnette, C.P.M.
(970) 221-6707

Any questions regarding this inquiry should be directed to Ed Bonnette, (970) 416-2247. Please refer technical questions to Merv Perkins (Display Devices) @ 303-882-1805.

BIDDING GUIDELINES:

The City has indicated a Preferred Brand for each item listed on the bid. The bidder may elect to offer an "or equivalent" brand as an option. The City will be the final judge as to whether the "equivalent" brand is acceptable in lieu of the Preferred brand requested.

The City reserves the right to make awards on a Line Item basis or on a Total Bid basis; whichever is most beneficial to the City.

All bids must include freight F.O.B. Destination, Freight Prepaid. All freight charges must be included in prices submitted on proposal.

Lead time for delivery must be indicated for all items. The City reserves the right to consider Delivery Date as a basis for award of this quotation. Equipment needs to be installed in Fort Collins (by a third-party installer, already under contract to the City) April 1-15, 2003.

QUANTITY:

1 each

DESCRIPTION:

Marshall Furniture Custom Podium, Drawing #10445

\$ _____ Ea. \$ _____ Total

Mfr. _____ Mfr. # _____

Delivery: _____

Items being bid meet the above specifications without exception.
Yes ___ No ___. If not, please list exceptions, specifying paragraph reference number, on a separate sheet and attach to your bid.

p. 1 of 6

QUANTITY:

1 each

DESCRIPTION:

Extron 5CR Switcher/system controller

\$ 2093.75 Ea.

\$ 2093.75 Total

Mfr. EXTRON

Mfr. # 60-269-02

Delivery: APPROX. 1 WEEK

Items being bid meet the above specifications without exception.
Yes No If not, please list exceptions, specifying paragraph reference number, on a separate sheet and attach to your bid.

QUANTITY:

1 each

DESCRIPTION:

Extron RGB440 60-268-01 VGA to RGBHV Interface with audio buffering

\$ 568.75 Ea.

\$ 568.75 Total

Mfr. EXTRON

Mfr. # 60-268-01

Delivery: APPROX. 1 week

Items being bid meet the above specifications without exception.
Yes No If not, please list exceptions, specifying paragraph reference number, on a separate sheet and attach to your bid.

p. 2 of 6

QUANTITY:

1 each

DESCRIPTION:

Extron 26-502-02-LBC 90 VGA HR 6' cable

\$ 100.00 Ea. \$ 100.00 Total

Mfr. EXTRON Mfr. # 26-502-02

Delivery: APPROX. 1 week

Items being bid meet the above specifications without exception.
Yes ___ No ___ . If not, please list exceptions, specifying paragraph reference number, on a separate sheet

QUANTITY:

1 each

DESCRIPTION:

AMX AXCENT3-PRO Control System

\$1700.00

\$ _____ Ea. \$ \$1700.00 Total

Mfr. AMX Mfr. # Accent 3 Pro

Delivery: APPROX. 7-10 Days

Items being bid meet the above specifications without exception.
Yes ~~___~~ No X . If not, please list exceptions, specifying paragraph reference number, on a separate sheet

Price is for accent 3 pro only.

QUANTITY:

1 each

DESCRIPTION:

AMX AXD-CV10 10.4" Touch Panel with Video Display (Black)

\$ 5150.00 Ea. \$ 5150.00 Total

Mfr. AMX Mfr. # AXD-CV10

Delivery: APPROX. 7-10 Days

Items being bid meet the above specifications without exception.
Yes ___ No X . If not, please list exceptions, specifying paragraph reference number, on a separate sheet

Price is for AXD-CV10 - only.

p. 3 of 6

QUANTITY:

1 each

DESCRIPTION:

Extron ADA2 300MX-1 in 2 out RGB HV DA Amplifier

\$ 350.00 Ea.

\$ 350.00 Total

Mfr. Extron

Mfr. # ADA 2 300 HL

Delivery: APPROX. 1 week

Items being bid meet the above specifications without exception.
Yes ___ No X. If not, please list exceptions, specifying paragraph
reference number, on a separate sheet

1 in 2 out RGB HV DA AMPLIFIER

QUANTITY:

1 each

DESCRIPTION:

Tascam M-243 Audio Mixer

\$ _____ Ea.

\$ _____ Total

Mfr. _____

Mfr. # _____

Delivery: _____

Items being bid meet the above specifications without exception.
Yes ___ No _____. If not, please list exceptions, specifying paragraph
reference number, on a separate sheet

QUANTITY:

1 each

DESCRIPTION:

RDL STM-2 Phantom Power Supply with line level out
(includes 24V supply)

\$ _____ Ea.

\$ _____ Total

Mfr. _____

Mfr. # _____

Delivery: _____

Items being bid meet the above specifications without exception.
Yes ___ No _____. If not, please list exceptions, specifying paragraph
reference number, on a separate sheet

p. 4 of 6

QUANTITY:

1 each

DESCRIPTION:

Middle Atlantic Rack Mount Kit for monitor

\$ _____ Ea. \$ _____ Total

Mfr. _____ Mfr. # _____

Delivery: _____

Items being bid meet the above specifications without exception.
Yes ___ No _____. If not, please list exceptions, specifying paragraph
reference number, on a separate sheet

QUANTITY:

1 each

DESCRIPTION:

Middle Atlantic Rack Mount Kit for VCR

\$ _____ Ea. \$ _____ Total

Mfr. _____ Mfr. # _____

Delivery: _____

Items being bid meet the above specifications without exception.
Yes ___ No _____. If not, please list exceptions, specifying paragraph
reference number, on a separate sheet

QUANTITY:

2 each

DESCRIPTION:

Infinity Outrigger 8 ohm loud speakers

\$ _____ Ea. \$ _____ Total

Mfr. _____ Mfr. # _____

Delivery: _____

Items being bid meet the above specifications without exception.
Yes ___ No _____. If not, please list exceptions, specifying paragraph
reference number, on a separate sheet

p. 5 of 6

5/6/98

QUANTITY:

1 each

DESCRIPTION:

Extron 26-614-02-LBC 90 right angle cable HR 6'

Couldnt find this part #

\$ _____ Ea. \$ _____ Total

Mfr. _____ Mfr. # _____

Delivery: _____

Items being bid meet the above specifications without exception. Yes _____ No _____. If not, please list exceptions, specifying paragraph reference number, on a separate sheet

Vendor Name: SPECTRUM Audio Visual

Address: 351 W. 45th AVE,

Telephone # 303-477-4456 FAX # 303-477-3348

Respondent Name: JAMENE Klym
(Please Print)

By: [Signature]
(Signature)

p. 6 of 6